

ELECTRICAL COMMUNICATION

JANUARY

No. 3

1931

VOL. 9

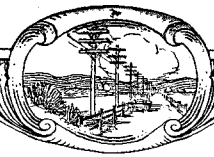

ELECTRICAL COMMUNICATION

A Journal of Progress in the
Telephone, Telegraph and Radio Art

H. T. KOHLHAAS, Editor

EDITORIAL BOARD

J. L. McQuarrie F. Gill G. Deakin P. E. Erikson G. H. Nash M. K. McGrath
G. E. Pingree P. K. Condict E. A. Brofos E. C. Richardson Frank C. Page

Published Quarterly by the

International Standard Electric Corporation

Head Offices

67 BROAD STREET, NEW YORK, N. Y., U. S. A.

European General Offices

CONNAUGHT HOUSE, ALDWYCH, LONDON, W. C. 2, ENGLAND

G. E. Pingree, President

L. N. Rock, Secretary

James E. Fullam, Treasurer

Subscription \$3.00 per year; single copies 75 cents

Volume IX

JANUARY, 1931

Number 3

CONTENTS

ELECTRICAL COMMUNICATION IN 1930.....	157
<i>By Sidney Brooks</i>	
AUTOMATIC TELEPHONY IN BERGEN, NORWAY.....	161
<i>By Sigurd Indrehus</i>	
ROTARY AUTOMATIC IN SWITZERLAND.....	169
<i>By Gerald Deakin</i>	
THE SELECTOR SYSTEM OF SUPERVISORY REMOTE CONTROL AS APPLIED TO THE GREAT INDIAN PENINSULA RAILWAY	174
<i>By W. R. Davies</i>	
THE SECOND NIIHAMA-SHISAKAJIMA SUBMARINE POWER CABLE.....	184
<i>By J. R. Pheazey</i>	
NEW LONG WAVE COMMERCIAL RADIO TELEPHONE-TELE- GRAPH TRANSMITTERS.....	189
<i>By D. B. Mirk and S. G. Knight</i>	
THE NEW STANDARD ECHO SUPPRESSOR.....	196
<i>By W. F. Marriage, B.Sc., A.M.I.E.E., P. R. Thomas, B.Sc., A.M.I.E.E. and K. G. Hodgson, B.A.</i>	



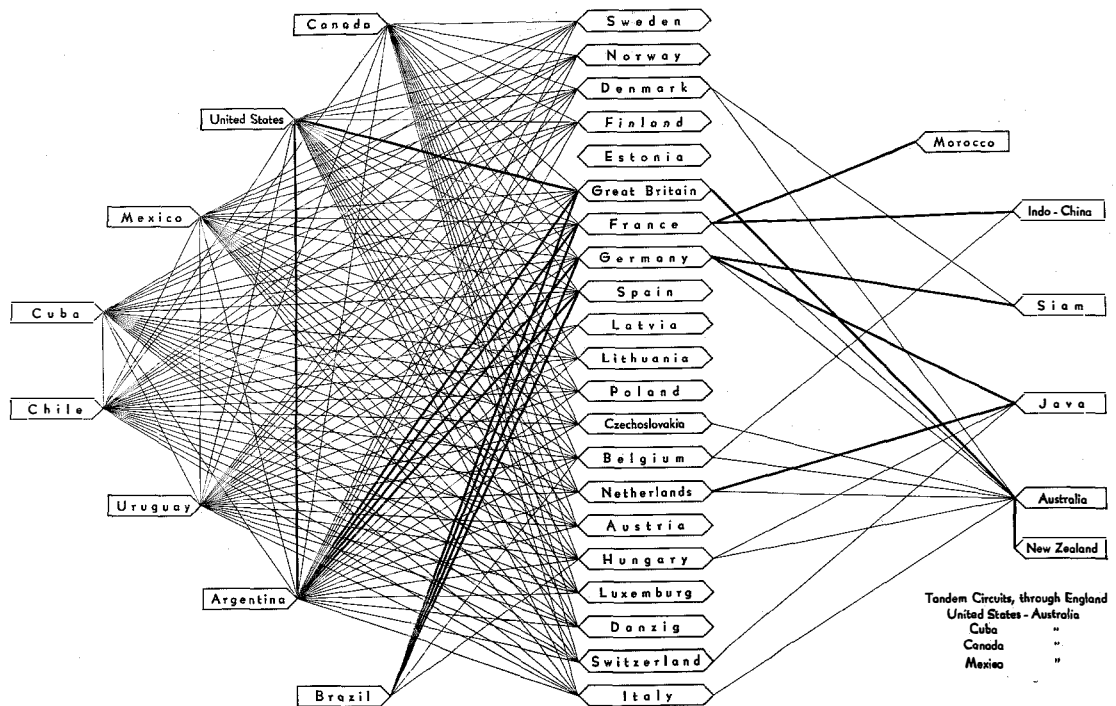

INTERNATIONAL TELEPHONE CONNECTIONS AVAILABLE
THROUGH RADIO TELEPHONE CIRCUITS

December, 1930

Heavy lines in the chart indicate direct radio circuits; light lines, radio circuits plus land line extensions.

Outstanding are the direct network-to-network radio services, where subscribers at either end can talk from their home or office telephones. These are: Argentina-Spain; Argentina-Germany; Argentina-France; Argentina-Great Britain; Argentina-United States; United States-Great Britain and Great Britain-Australia. The International Telephone and Telegraph System operates the Argentine-Spanish service; also the Argentine ends of the German, French, British, and United States services. The British Post Office operates the British ends of the British-Australian, the British-Argentine and the British-United States services. The American Telephone and Telegraph Company operates the United States ends of the British-United States and Argentine-United States services. The Australian end of the British-Australian services is operated by Amalgamated Wireless (Australasia) Ltd.

Electrical Communication in 1930

By SIDNEY BROOKS, Information Service Manager

International Telephone and Telegraph Corporation

International Telephony

PROGRESS in international telephony during 1930 was even greater than in the previous year. Radio telephony at the beginning of 1929 provided daily telephone service to more than twenty-six countries. Connections were made by point-to-point radio circuits supplemented by land line extensions from radio terminals. During 1929 and 1930 more than twice as many new international connections were established, eleven by means of point-to-point radio circuits and an additional ninety-two fed into these circuits by land line extensions. The total of international connections wholly or partly effected through radio telephony was thereby increased to one hundred and seventy-seven (see Frontispiece).

Three of the 1930 groups of connections, because of the fact that they provide network-to-network connections, stand out as of leading importance. The first was established between North and South America, linking the United States, Canada, Cuba, and Mexico on the one end with Argentina, Chile, and Uruguay on the other.

The second group involves three new channels between Europe and South America. They operate from Paris, Berlin, and London to Buenos Aires. Land line connections bring a total of twenty other countries into these circuits, viz: Austria, Belgium, Chile, Czechoslovakia, Danzig, Denmark, Finland, Italy, Hungary, Latvia, Lithuania, Luxemburg, Netherlands, Norway, Poland, Sweden, Switzerland, and Uruguay.

The third group involves the London-Sydney circuit, a distance of 9,192 miles, together with its extension through London to New York over the north transatlantic circuit. These circuits supplemented by land line extensions connect most of the telephone subscribers of the United States, Canada, Cuba, Mexico, Great Britain, Hungary, and Italy, with Australia.

Other point-to-point radio telephone circuits opened during 1930, some of which involve network connections at one end, include those be-

tween Rio de Janeiro, Paris, Berlin, and Madrid; Berlin and Java; and Paris and Morocco.

There are also under construction or projected, point-to-point radio channels between the United States and Australia (direct); between the United States and Japan, the Philippines and Honolulu; between Great Britain and Canada, India, South Africa, China, and Japan. During the year tests were carried on between Buenos Aires and Sydney, Japan and New Zealand; between Buenos Aires and Java via Berlin and many other points.

Particularly spectacular were: a conversation transmitted around the world from Schenectady, New York, and then broadcast; conversations carried on by Captain Lewis Yancey in an aeroplane over the city of Buenos Aires through the Buenos Aires station of the Compañía Internacional de Radio (Argentina) with points in the United States, with the S.S. "Majestic" on the high seas, and with Sydney, Australia, a distance of more than 14,000 miles.

Long Distance Telephony

Growth in long distance telephone services throughout Europe and the world continued during 1930, communication having been opened up between several additional countries and in some cases expanded to include whole districts or countries rather than a single town.

The vast European toll cable network was added to during 1930 to the extent of some six to eight thousands of kilometres of cable with about 1½ millions of kilometres of copper conductors, in addition to large quantities of loading coils and repeaters. Two new submarine cables were laid across the English Channel and one between Sweden and Germany.

It may be of interest to remark in passing that of the European long distance cable systems, some 40% of the materials have been supplied and in many cases the projects involved have been completely engineered and installed by the International Standard Electric Corporation's associated manufacturing and affiliated cable companies. Included among the activities of

these companies and others throughout the world are cable projects in Argentina, Chile, China, Belgium, Czechoslovakia, Denmark, France, Great Britain, Holland, Hungary, Italy, Japan, Poland, Spain, Sweden, Switzerland, and Uruguay.

In Great Britain during 1930, an early cable between London and Liverpool with heavy gauge conductors varying from 100 lbs. to 300 lbs. per mile has been withdrawn and replaced by a modern cable with 25 lbs. per mile conductors, a change which effected large economies and a great increase in the number of circuits provided.

Italy's cable system, which increased considerably in 1930, brought the peninsula for the first time into adequate telephone communication with the other European countries, and provided means for numerous extensions into Eastern Europe as far as Yugoslavia, and connection with the rest of the world by means of the radio telephone.

In Hungary, the cable network has been extended south to link up with Rumania and Yugoslavia. In Spain, the first section of an underground cable has been completed from Madrid towards Barcelona. In Rumania, an underground network to connect with surrounding countries is being planned and installation of the first section will be started in 1931.

In China, the laying of the Hong Kong-Canton cable is part of the plan of the Nationalist Government for building up long distance telephony.

Estonia and Lithuania were connected with many European countries including Great Britain. Connection was also established between Berlin and Moscow. An important event was the opening of telephone communication between Vatican City and many European countries.

Mexico during 1930 made additional connections with the United States, and Guatemala and El Salvador made their first international telephone connections. Traffic with Cuba necessitated the laying of a fourth telephone cable between Havana and Key West. The new cable will provide three telephone circuits by means of carrier current systems in addition to a voice frequency telephone circuit especially arranged for broadcasting.

The rapid development of long distance tele-

phony may be seen by reference to the International Telephone Directory (A. T. I.). When first published in 1929 it contained about 12,000 entries from 1,485 towns in 27 different countries. The 1930 edition contains more than 50,000 entries from 2,718 towns in 38 countries.

Radio Telephony in Mobile Services

The most substantial advance in mobile radio telephone services was made in ship-to-shore telephony. Ship-shore and shore-ship services were first opened in 1929 between the S.S. "Leviathan" and the United States, and between the S.S. "Majestic" and England. In 1930 they were extended to include the "Majestic" and the United States, the "Leviathan" and Europe, the "Olympic" and the "Homeric" with both sides of the Atlantic, including Canada, Cuba, Mexico, Belgium, Germany, Netherlands, France, Spain, Switzerland, Austria, Denmark, and Sweden. These services were made possible by the cooperation of the British Post Office, the American Telephone and Telegraph Company, and the International Telephone and Telegraph Corporation.

In April, commercial radio telephone service was started on the Canadian National Railway's Montreal and Chicago express by conversations with England. This service will be extended to include the Grand Trunk Railway.

Considerable equipment has been ordered for aeroplane telephone service along American air routes, and the Aeronautics Division of the U. S. Department of Commerce has announced a plan for transmitting telephone messages along radio beacon channels. In England, the radio telephone is being utilized to instruct students during the hazardous first solo flight.

Automatic Telephony

Conversion throughout the world from older systems to automatic working is proceeding rapidly. Increase in automatic lines in Europe during 1930 was of the order of 20%.

Highly satisfactory automatic services in the larger towns has brought about an increasing demand for better telephone facilities in rural areas and many Administrations are turning their attention to this problem. In Switzerland, the districts around Lausanne and Zürich have

been converted to automatic working and the Administrations of Czechoslovakia, France, Great Britain, Hungary, and others are evincing great interest in this problem and are installing rural automatic equipment.

In Paris, automatic equipment has met with decided public approval. Three new Rotary automatic exchanges were opened during the year and three more have been ordered.

The Rotary installation for the entire city of Brussels was completed during the year, and the program for equipping Budapest with Rotary is well towards completion. In November, the Vatican City Rotary automatic equipment was cut into service.

Complete conversion to automatic working continued in London. In South America also, installation of automatic equipment has proceeded rapidly, particularly in Santiago and Valparaiso, Chile, and in Buenos Aires and Rio de Janeiro.

Rotary automatic equipment was installed in Cairo and Alexandria, Egypt, during the year. An agreement was reached with the International System for taking over the Shanghai Telephone Company. Shanghai's system will be re-built and Rotary automatic equipment installed. In these cities where the people speak many tongues, both native and foreign, automatic telephony has a peculiar value because of the difficulty of obtaining polylingual operators.

In Spain, the program for complete modernization of the telephone system including Rotary installations in some twenty cities was completed in August, 1930, giving Spain the most modern national telephone system in Europe if not in the world. In view of the unique Spanish achievement, the Rumanian Government in June signed a contract with the International Telephone and Telegraph Corporation for similar complete modernization of the telephone services in that country including the provision of Rotary automatic equipment in all principal cities, with thorough re-building of the local networks and the installation of a long distance underground cable system.

The great increase in the use of automatic telephone equipment in Europe has led to a demand for direct dialing over long distance lines, a problem which was solved successfully during the year. Early demonstrations and tests in

Dusseldorf and Brussels on the occasion of the Conference of the Comité Consultatif International des Communications Téléphoniques à Grande Distance, when direct keysending was successfully carried out to subscribers in the London automatic area, have been followed by the installation of permanent equipment in many countries.

Radio Telegraphy

The year 1930 brought nearer to realization the goal of a complete world network of radio telegraph channels. Great Britain, during 1930, inaugurated a beam wire telegraph channel between England and Japan which replaced the one way service from England; also, a high speed service between London and Teheran, Persia. France, in the process of merging its services, opened circuits with Turkey and commenced the work of providing equipment for joint radio telegraph and telephone channels with Algiers. Spain provided a service with Manila, Philippine Islands.

Service was opened between Shanghai, China, and the United States and Germany and is to be extended to Paris. From the United States a new direct service was set up across the Pacific to Manila.

Japan started negotiations for a direct service to India and completed arrangements for service to the South Sea Islands.

Services were opened between Chile, Panama City, and New York, and between San Francisco and Guaymas, Mexico, on the Gulf of California; between Mexico and Spain; Cuba and Porto Rico. A service is also projected between Cuba and Germany.

In Africa, new radio channels include those between Cameroon and Togo and the Ivory Coast, Dahomey, French Guinea, Mauretania, and Senegal; Portuguese East Africa and the Portuguese colony of St. Thome and Principe. A new station was opened at Dilolo, Belgian Congo.

Considerable progress during 1930 was made in radio beacon service to ships at sea and to aeroplanes.

Broadcasting

In 1929, broadcasting of speeches across the Atlantic was an innovation; in 1930, it was a

quite common occurrence. At the depositing of the Naval Treaty in London in October, the speeches of the Japanese Prime Minister in Tokyo, the American President in Washington, and the British Prime Minister in London, were broadcast successfully to a listening world.

Another notable event occurred at the time of the convention of the National Electric Light Association at San Francisco last June, when speeches by distinguished men were exchanged between England, Germany, and the United States.

Picture Transmission and Television

Commerical facsimile or picture transmission services are being furnished the public in Great Britain, Germany, Sweden, Japan, Denmark, Canada, and the United States.

In Europe, the television systems of greatest prominence are the Baird and the Mihaly which are marketed in the form of receivers for picking up broadcast pictures. In the United States, results with two-way television obtained by the Bell Telephone Laboratories are most promising.

Automatic Telephony in Bergen, Norway

By SIGURD INDREHUS

Telephone Engineer

WHEN it became necessary, about 1912, to replace the local battery telephone exchange in Bergen, a change-over from overhead lines to underground cables was nearing completion. A new telephone building originally planned for C. B. manual service was in construction, and tenders were invited for three alternative systems: C. B. manual, semi-automatic, or full automatic. Consideration of these offers and systems led to the decision to install the Rotary automatic system, and a contract was signed by the Bell Telephone Manufacturing Company, Antwerp, and the Bergens Telefonkompani. The system decided upon was a mixed semi and full automatic system, equipped with 4,620 semi-automatic and 420 full automatic subscribers' lines. The handling of rural traffic and traffic from the toll exchange was based upon manual service, and for this purpose a manual multiple switchboard was to be provided.

As, however, it was intended gradually to place the entire service on a full automatic basis the initial installation was designed to facilitate this conversion. In adopting the mixed system, the two controlling factors were—first, that it would permit a gradual reduction of operators during the conversion period, and second, that the cutover could be made without much trouble to existing subscribers' installations, the local battery sets being rendered suitable both for local battery and semi-automatic service by the addition of 2 mf. condensers in series with the bells. Furthermore, there was some uncertainty as to how the full automatic service would suit the subscribers, and the introduction of a mixed system was calculated to furnish evidence on this point.

The new telephone building was ready and the installation begun in the fall of 1914. At the outset there was great difficulty in obtaining materials on account of the War, and the work was considerably delayed, notwithstanding vigorous efforts to speed up progress. Thus, though the installation was originally planned for com-

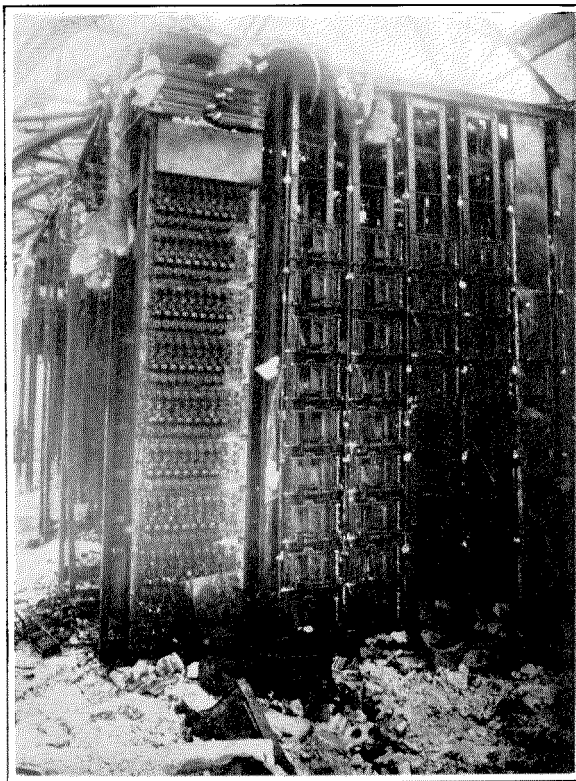

Figure 1—Automatic Equipment After the Fire.

pletion in 1914, it was not until January, 1916, that work had progressed far enough for tests to be made. During the testing period, however, Bergen was visited by a great conflagration which, in the course of a few hours, destroyed the central part of the city including 380 houses and the ill-fated new telephone exchange. The realization of automatic and semi-automatic service had therefore to be further deferred.

Figure 1 shows parts of the destroyed automatic equipment. Although the brick walls and reinforced concrete flooring resisted the tremendous heat, the automatic equipment was of course destroyed. Bergen's telephonic misfortunes, however, did not end here; the existing manual telephone exchange then serving Bergen was also completely destroyed in the fire, and the city was temporarily without telephone

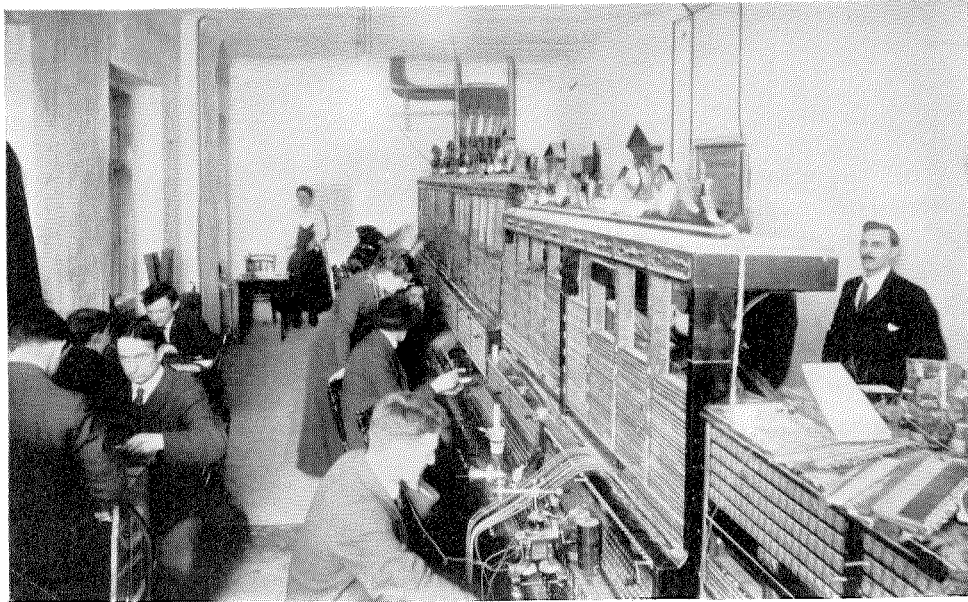

Figure 2—Temporary Installation After the Fire.

service. Although the damage to the new telephone building was considerable, it was not beyond repair, and a temporary restoration was started immediately.

The urgent task now was to establish some sort of telephone service as quickly as possible. There was no time to get new equipment, but some old local battery multiple switchboards which had been stored away were brought out, and their installation begun within a few days of the fire. As the fire had left the new telephone building without a roof some difficulty was encountered in keeping the installations dry. Fortunately, however, the engineers and installers of what was then the Western Electric Company, were on the spot and ready to undertake the work of bringing the old local battery switchboards into usable condition. Within a few days it was possible to connect some of the public offices and important business houses to a temporary switchboard (Figure 2) and the installation of the old switchboards progressed continuously day and night.

While the wiring in the houses in the fire area was damaged, the underground cables

were not affected, and the cable vault and cable shaft in the new telephone building also escaped damage. The lead-covered silk and cotton insulated cables from the vault to the main distribution frame were burnt at the frame, but were not otherwise damaged. After being cut at the main distribution frame, these cables were in good condition and a temporary frame was erected at the end of the cable shaft and connected to the temporary switchboard. In this way about 2,000 subscribers were connected, and the necessary junctions to the toll exchange and to the rural districts were installed. A 1,000 line C. B. manual switchboard and a 450-line local battery switchboard were installed later.

As the Bell Telephone Manufacturing Company, Antwerp, was unable to rebuild the automatic exchange on account of the war conditions in Belgium, the old Western Electric Company, Limited, of London (now Standard Telephones and Cables, Limited), undertook the work; and as it was essential to have the automatic exchange in service as soon as possible, it was decided to rebuild the exchange

in accordance with the original plans. The front of the building after temporary reconstruction is seen in Figure 3.

The new exchange had to be equipped for 4,620 semi-automatic and 1,020 full automatic subscribers' lines, and the traffic from the toll exchange and from the rural districts was to be handled manually. The automatic switches were calculated on the basis of each subscriber making 9.5 calls a day, and on a holding time of 90 seconds.

The main part of the equipment was scheduled to be delivered from the United States, as it was considered very unlikely that the Western Electric factories in England and France would be permitted to export telephone material under war conditions. Numerous troubles were experienced in obtaining the material, and when the United States entered the war the position became still more difficult. At last these difficulties were surmounted, and the new automatic exchange, was ready for opening in the spring of 1920.

The installation, which is on somewhat similar lines to previous semi-automatic installations

in Zürich and Marseilles, comprises 12 semi-automatic positions (Figure 4), each equipped with 18 connecting circuits and 2 registers. A manual multiple switchboard provided with 8 positions is also installed. Two of these positions are equipped with order wire junctions from the toll exchange, two accommodate the rural traffic, one position is used by the test operator, and three positions have been used for releasing automatic equipment during conversions, etc. These positions, which are equipped with C. B. subscribers' circuits and double cord circuits, have proved very useful. For supervision and information service a two-position chief operator's desk is installed.

The main and intermediate distribution frames, line and cutoff relays, battery charging machines, power board and batteries are installed on the floor below the switch room. An emergency power supply in the event of a failure in the public supply is provided by a gas-engine-driven 60 kw. D. C. set generating at 220 volts.

Following the opening of the exchange in the spring of 1920, there were some initial diffi-

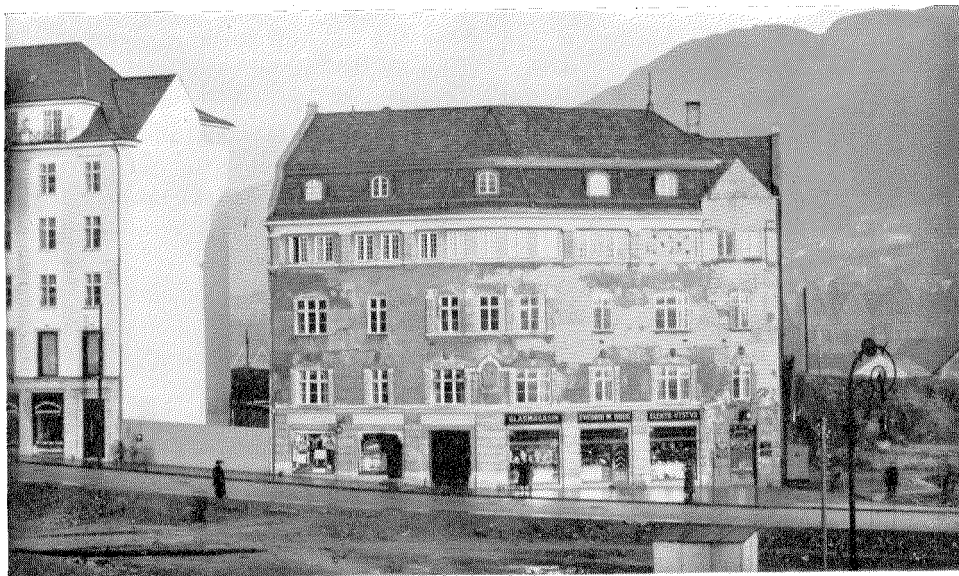

Figure 3—Bergen Telephone Building Temporarily Repaired After the Fire.

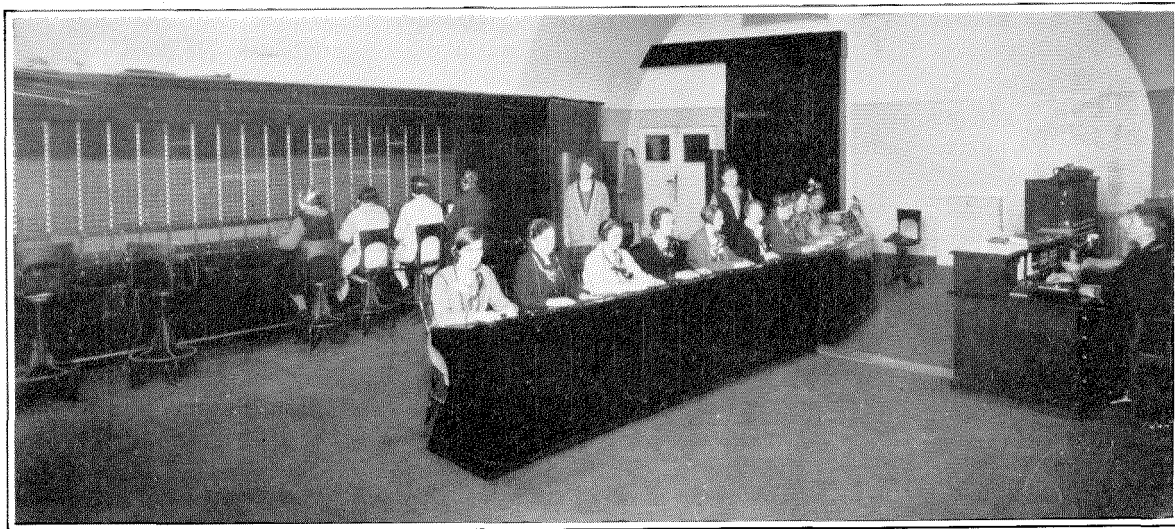

Figure 4—Semi-automatic Positions, Bergen Exchange.

culties due to traffic overload arising from busy trade conditions, and it was very difficult to obtain reliable traffic statistics at the temporary installations owing to the overloading of the manual switchboards during the busy hours. The traffic difficulties at the opening of the automatic exchange were mainly overcome by transferring subscribers to the manual C. B. multiple boards which were adopted to work in conjunction with the automatic exchange.

Investigations made at the time showed that while some subscribers were in favour of full automatic, others preferred semi-automatic. There was no doubt, however, that both systems were regarded with favour by the subscribers concerned. From the economic point of view the full automatic service was obviously preferable. Consequently, as an extension had become necessary, the company chose the full automatic system, and placed orders in 1920 for 1,020 additional full automatic lines and for the conversion of 1,000 lines from semi-automatic to full automatic. Some extensions of the connecting circuits were also ordered, and were installed in 1921 and in the early part of 1922. A further extension of 600 lines and a conversion of 1,500 lines from semi-automatic into full automatic was ordered in 1926.

For the maintenance of the exchange certain routine tests commonly adopted in previous automatic installations were introduced. These

tests were to a large extent performed by the manual sending of calls through the equipment under test.

As an example of procedure it may be mentioned that the test schedule in Bergen at that time provided for the regular testing and inspection of final selectors in such a way that each final was tested once every two weeks. Calls for the testing of finals had to be routed over the full automatic equipment, and a resistance of 100 ohms was put in series with the subscribers' set which was connected to the called line. Number 99 of the uneven hundred was called as giving the maximum of impulses. Each final selector was inspected for mechanical adjustment in accordance with standard maintenance specifications.

The testing of the second group selector was made in a similar way. The tests had to be done in the slack traffic hours in the evening, and during the night.

Close examination of the conditions showed that many of the tests made could be performed in a more reliable and more convenient way by automatic devices. The writer designed several automatic test sets for that purpose in 1921, and the experimental results obtained were encouraging. Early in 1922 an automatic test set for final selectors was installed for regular service, and was followed later by a test set for second group selectors and a set for

full automatic connecting circuits and registers.

It may be of interest to devote a few words to these test sets and the results obtained with them; for, so far as I know, they are the first automatic routine maintenance test sets to be utilized in conjunction with the No. 7-A full automatic telephone system. The final selector test circuit and the final selector circuits are both shown in Figure 5.

The circuit was designed to test the final selectors under working conditions. An additional limit test was performed for interruptors of the final selector, and a limit test was performed for the test relays FTR and PBR. The limit test for the interruptors was made by introducing a slow operating relay OSR. A final selector giving too short impulses would be discovered by the slow acting relay OSR in the test circuit.

The limit test for the final selector test relay was performed by adding resistance in series with the relay COR of the test circuit.

To start the test the operator plugs into the test jack of the final selector. If the selector

under test is free it operates and selects the last number in its multiple. When this number is reached the final selector is stopped by the test set, and ringing current is supplied to the relay RR of the test circuit.

The operation of the relay RR breaks down the connection, and the test operation is repeated as long as the plug remains in the test jack. If the final selector happens to be busy the test set remains unoperated until the final selector returns to the home position. Then the test set operates and performs the test in the usual way. If a fault occurs the test set stops and does not release.

The test set for the second group selectors is shown in Figure 6. The operation of this set is similar to that of the final selector test set, and with it the test operator is able to test all the second group selectors in a period of from three to four hours.

In Figure 7 is shown the circuit designed for testing the full automatic connecting circuits and registers. The test set consists of three sequence switches RI, RS, and RN. RI sends

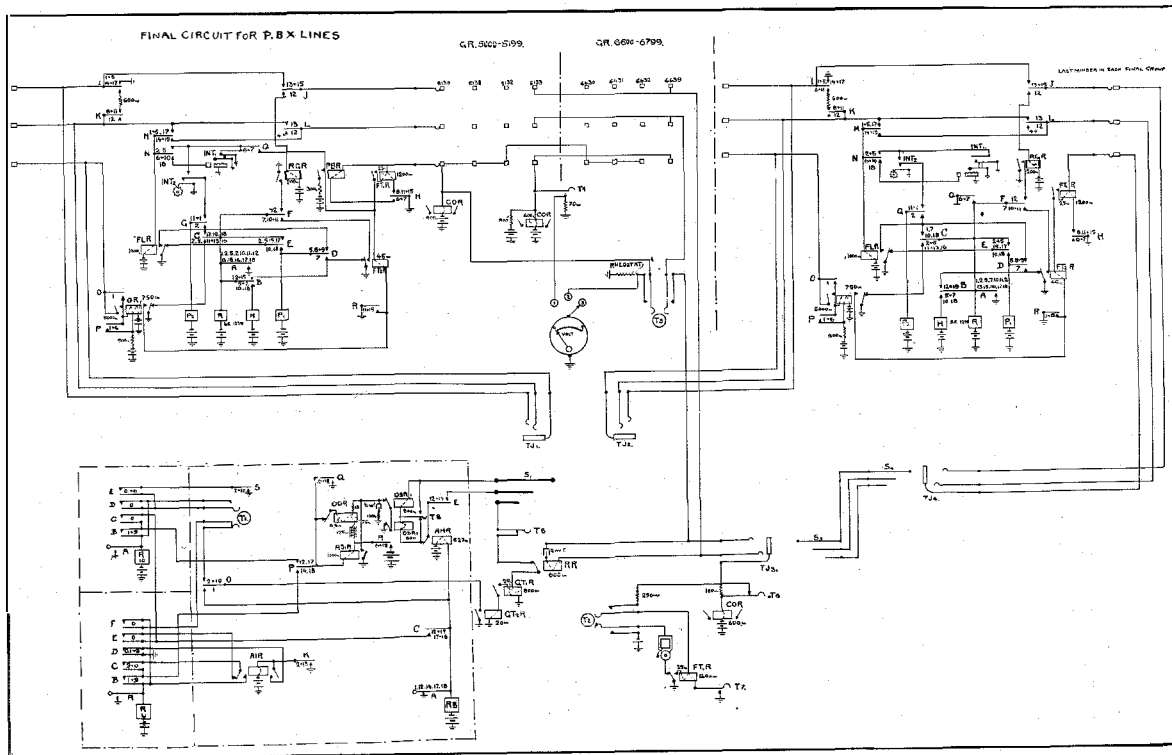

Figure 5—Automatic Test Set for Final Selectors.

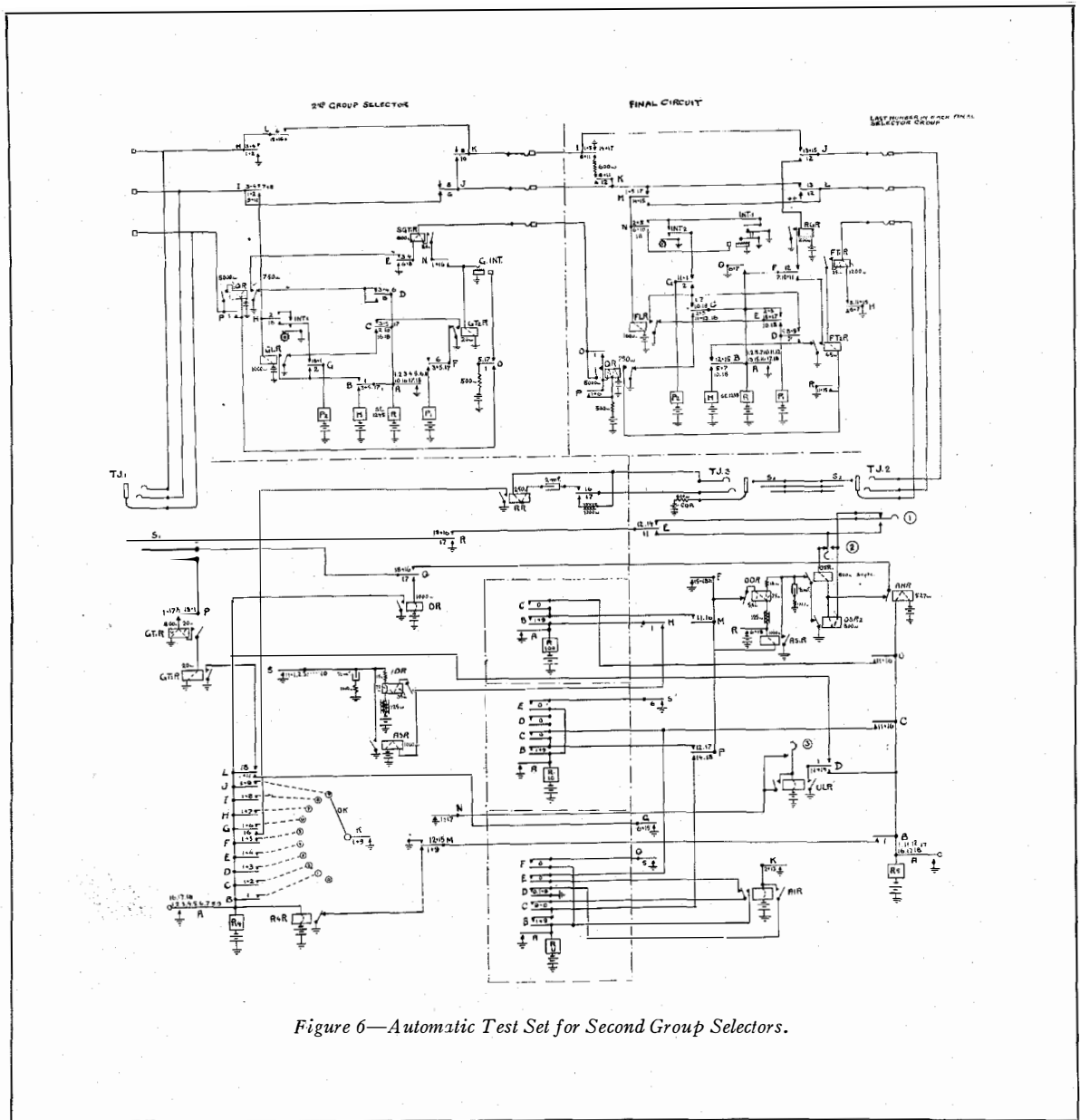

Figure 6—Automatic Test Set for Second Group Selectors.

the impulses to the full automatic registers. The circuit is connected to a subscriber's line and the operation is similar to that of a subscriber sending calls through the exchange.

The test circuit may be operated in the following way: The set is connected to a subscriber's line by the plug S. The set is, for example, arranged for sending in number 5199 by plugging P-1000 in jack J-5, P-100 in jack J-1, P-10 in the jack connected to P-1, and P-1 in the jack J-9.

When the sequence switch RS arrives at the positions 13, 14, 15, and 16 the sequence switch RI rotates and sends the impulses to the full automatic register. These impulses are identical with impulses from a dial sending the number 5199. Any desired number may be selected by plugging P-1, P-10, P-100, and P-1000 in the jacks J-0 to J-9 in the way shown.

The improvement in maintenance tests consequent on the introduction of this testing device has resulted in an improvement of the service.

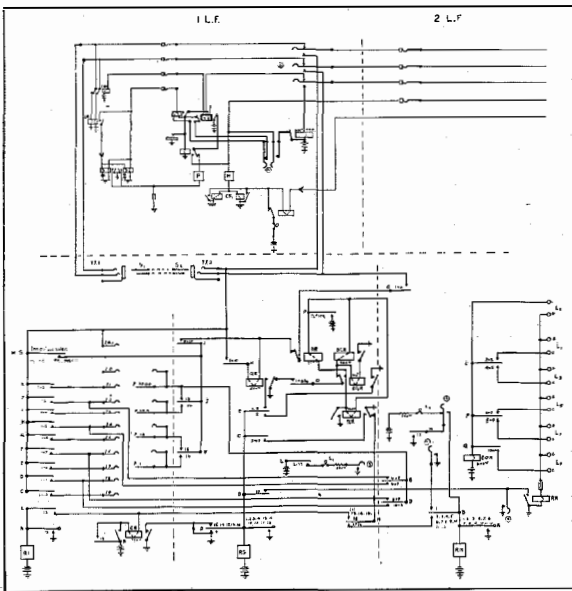

Figure 7—Automatic Test Set for Full Automatic Connecting Circuits and Registers.

Night-work was materially reduced, and this again resulted in decreased maintenance cost. In 1922 the maintenance cost of the exchange was reduced by 24% in spite of a considerable increase in equipment. This reduction was obtained chiefly through the introduction of the automatic test sets.

Bergen's telephone network was increased in 1929 by the opening of a new full automatic telephone exchange at Kronstad, a residential district about 4 km. from the Bergen exchange.

The equipment delivered by Standard Electric A/S, Oslo, was the latest Standard Electric No. 7-A Machine Switching System. The exchange equipment is for 1,200 lines (ultimate capacity 10,000 lines), and provision has been made for full automatic toll service. The total originating traffic is 1,995 busy hour calls and 1,343 equated busy hour calls.

Subscribers connected to Kronstad are allotted

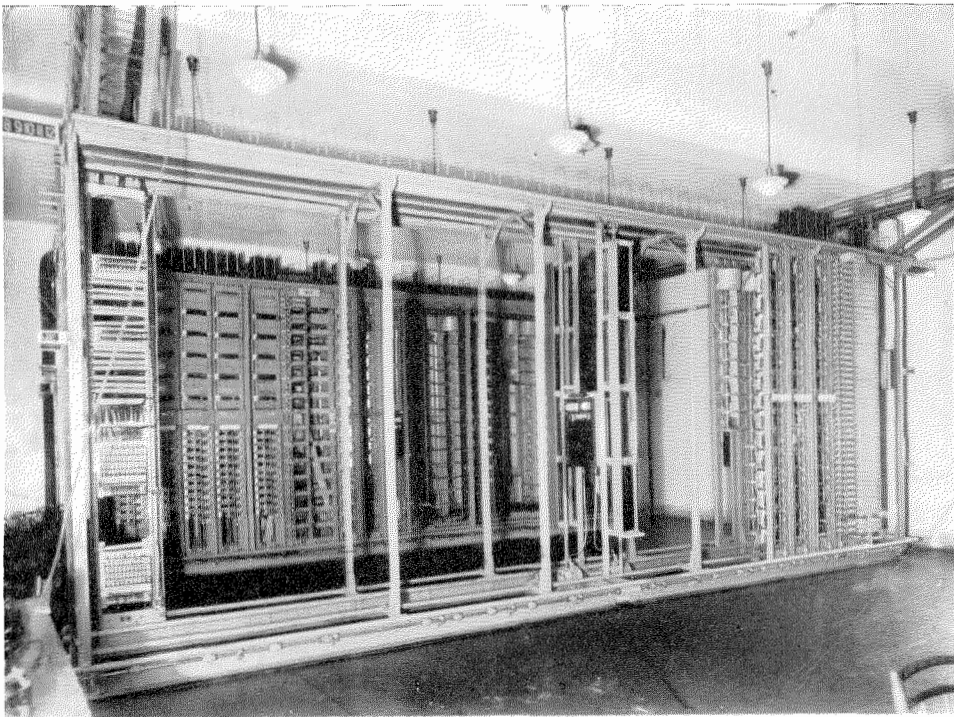

Figure 8—Automatic Equipment, Kronstad Exchange.

numbers 8,000 to 9,199, while subscribers connected to Bergen exchange use the numbers below 8,000.

The registers, which are of the relay type, are four-digit registers, and as the old rotary full automatic registers in Bergen were replaced by relay registers in 1928, both exchanges are uniform in this respect. At the same time some modifications of the full automatic connecting circuits were made at Bergen for the introduction of permanent glow, etc.

The telephone building for Kronstad, was finished early in 1929. Installation of the automatic equipment (a portion of which is seen in Figure 8) was started without delay, and the exchange was opened in December last. A junction diagram for the Bergen area is shown in Figure 9.

Test calls sent through the Kronstad exchange established the percentage of irregularities at 0.6%, a figure which approximates to that for Bergen. The performance of the automatic equipment has been entirely satisfactory.

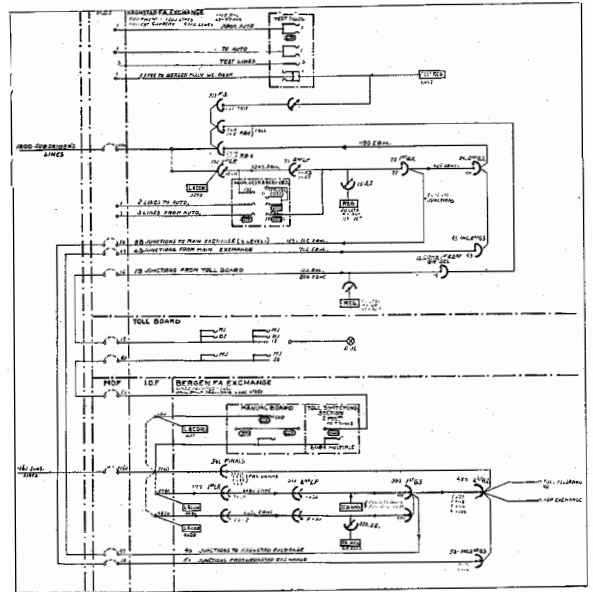

Figure 9—Junction Diagram for the Bergen Area.

Bergen was the first city in northern Europe to order an automatic system.

Rotary Automatic in Switzerland

By GERALD DEAKIN

First Assistant Chief Engineer, International Telephone and Telegraph Corporation

IN January, 1930, the last manual central office in Geneva was replaced by an automatic office of the rotary type, thereby placing Geneva with Zürich¹ on an all-automatic basis. Geneva, the seat of the League of Nations, is now served by three rotary automatic central offices and one satellite, totaling approximately 22,000 lines; and Zürich, the commercial center of Switzerland, by four rotary central offices and five satellites, totaling about 32,000 lines with some 10,000 additional lines in the process of installation. Basle, the banking center of Switzerland, is served by one rotary automatic central office and three automatic satellites, totaling some 6,000 lines, and also by one manual office of approximately 7,000 lines.

Table I which is published with the permission of the Swiss Government gives the result of the service observations made in the cities mentioned for the first six months of 1930. The observations were recorded by trained operators on actual calls and include every call cut in on by the operator regardless of whether dialing followed the removal of the receiver from the switchhook.

It will be noted that the percentage of effective calls, that is, calls which resulted in successful conversations, was well above 80%, and for Geneva, even slightly over 85%. The total equipment failures in the two cities entirely converted to automatic was one-half of one percent or less, or in other words, one call or less out of every 200 attempted failed to result in a successful connection due to any equipment failure. In Basle, where the city is only partially converted to full automatic operation and where the observations included calls completed over call indicator equipment to the manual board, the equipment failures amounted to slightly more than seven-tenths of one percent or approximately seven failures per 1,000 calls.

¹See "Automatic Telephony in the Zürich Area," by E. Wollner, *Electrical Communication*, October, 1929, and "A Rural Rotary Automatic Telephone System Installed at Herrliberg," by W. Hatton, *Electrical Communication*, July, 1929.

In Zürich and Geneva which are served exclusively by automatic equipment, it is interesting to note that wrong numbers due to failures of the automatic equipment were almost entirely absent. In Zürich such failures were seven-hundredths of one percent and in Geneva eight-hundredths of one percent or less than one wrong number in each 1,000 calls originated by the subscribers. In Basle this type of error while still very low, less than one-half of one percent, was higher because of the fact that call indicator equipment entered into a large portion of the calls.

The total absence of observed failures in Zürich and Geneva due to all paths being busy, as well as the practical absence of this failure in Basle which, as before stated, involved some manual equipment, deserves particular attention. The reason for this very satisfactory state of affairs is the use of "continuous hunting" with a register, a combination which is found only in the rotary system. When all trunks are found busy on the first test, the switch in this system continues to hunt and will continue hunting until a junction becomes free, or until the subscriber hangs up, whereas in all other systems the call is lost if, at the instant of test, a junction in the group under test is not found free. By hypothesis, one call out of every 100 is generally lost during the busy hour in non-hunting systems since switches are usually calculated on this basis. To make a proper comparison between the performance of the rotary system with continuous hunting and the performance of an equally well maintained non-hunting system, the percentage of calls lost due to all paths being found busy should therefore be added to the total equipment failures. So compared, the writer doubts whether any non-continuous hunting system can meet the low failure record of the rotary system.

Table II contains the monthly service observation figures for the new Geneva Stand Central offices of 15,000 lines which were placed in service on January 25, 1930. It will be noted that

equipment failures have decreased steadily since the time of cut-over from 1.33% in January to the very remarkable figure of 0.09 of 1% during June when one failure due to the equipment was recorded out of a total of 1,045 calls ob-

served. The percentage of effective calls reached the high figure of 88.33, in this case, however, helped by a low percentage of "busy" and "no reply" calls.

An examination of the figures in Tables I and

TABLE I
SUMMARY OF SERVICE OBSERVING RESULTS—7-A ROTARY EQUIPMENT
SWITZERLAND
DATA SHOWN REPRESENTS RESULTS FOR FIRST SIX MONTHS OF 1930

City	Total Observations	Effective Calls %	Busy Calls %	No Reply Calls %	Ineffective Calls Due To:										Total Equip. Failures %
					Subscriber			Total Sub. Errors %	Machine Equipment						
					Wrong Number %	Faulty Usage %	Other Reasons %		Wrong Number %	Hang Up %	Interrupted %	Paths Busy %	Other Reasons %		
Zürich.....	55128	82.00	8.42	3.23	.94	4.30	.67	5.91	.07	.19	.0217	.45	
Geneva.....	20698	85.67	6.18	3.64	.98	2.35	.70	4.03	.08	.24	.0711	.50	
Basle.....	13592	83.92	7.71	1.61	.74	4.27	1.05	6.06	.44	.07	.05	.03	.12	.71	

TABLE II

SERVICE OBSERVATIONS
RESULT OF CALLS
PERIOD: 1930

AREA: GENEVA
EXCHANGE: STAND CENTRE I AND III
PUT IN SERVICE: 25TH JANUARY, 1930

MONTH	Number of Observations	Effective Calls %	Busy Calls %	No Reply Calls %	Ineffective Calls Due To:										Total Equip. Failures %
					Subscriber			Total Sub. Errors %	Machine Equipment						
					Wrong Number %	Faulty Usage %	Other Reasons %		Wrong Number %	Hang Up %	Interrupted %	Paths Busy %	Other Reasons %		
1	2	3	4	5	6	7	8	9	10	11	12	13	14	15	
January.....	1130	80.25	5.93	4.7	0.19	6.90	0.70	7.79	0.09	0.97	0.27	1.33	
February.....	4552	81.89	7.03	4.28	0.72	4.70	0.43	5.85	0.11	0.59	0.07	0.18	0.95	
March.....	4123	85.03	6.76	3.57	0.85	2.48	0.58	3.91	0.10	0.41	0.15	0.07	0.73	
April.....	3770	86.5	5.94	4.19	0.79	1.86	0.45	3.10	0.05	0.16	0.06	0.27	
May.....	2224	85.07	6.25	4.87	1.21	1.62	0.80	3.63	0.09	0.09	0.18	
June.....	1045	88.33	4.69	3.35	1.25	1.62	0.67	3.54	0.09	0.09	

TABLE III
SUMMARY OF MAINTENANCE FOR THE LARGER SWISS OFFICES
Data Shown Represents Average Figures for the First Nine Months of 1930

ITEM	ZÜRICH		BASLE	GENEVA	
	Hottingen Limmat	Selnau Uto	Safran	Stand	Mont Blanc
Number of lines equipped (satellites included).....	19,700	17,400	8,400	12,000	7,280
Number of maintenance men (WC and MDF excl.).....	20.9	19.5	8.6	13.8	9.4
Number of man hours per line per year (WC and MDF excl.)	2.8	2.7	2.5	2.8	3.1
Number of maintenance men (WC and MDF incl.).....	27.5	28.5	10.6	16.	11.
Number of man hours per line per year (WC and MDF incl.)	3.4	3.9	3.0	3.2	3.6

TABLE IV

MAN HOURS FOR MAINTENANCE
PERIOD: 1929

AREA: GENEVA. EXCHANGE: MONT BLANC
FULL AUTOMATIC+TOLL SERVICE

Month	Number of Technical Men	Number of Men	Number of Women	Total Number of Man Hours (Techn. Men Excep.)	Number of Lines	Number of Man Hours Per Line & Per Month
January.....	1/4	3	2	975	4274	13' 40''
February.....	1/4	3	2	944	4301	13' 10''
March.....	1/4	3	2	988	4270	13' 50''
April.....	1/4	3	2	1000	4303	14' 10''
May.....	1/4	3	2	1032	4386	14' 6''
June.....	1/4	3	2	980	4420	13' 18''
July.....	1/4	3	2	1064	4432	14' 24''
August.....	1/4	3	2	1020	4435	13' 48''
September.....	1/4	3	2	992	4428	13' 26''
October.....	1/4	3	2	1064	4448	14' 21''
November.....	1/4	3	2	948	4476	12' 42''
December.....	1/4	3	2	1000	4530	13' 15''
Average.....	1/4	3	2	1000	4392	13' 41''

- Notes:—1. Number of hours worked by women.....46 hours per week or 2400 hours per year
2. Number of hours worked by men.....48 hours per week or 2500 hours per year
3. Number of men used per 1000 lines.....1.12
4. Number of man hours used per line per year.....2 hours 44'
5. Number of lines equipped.....5040
6. Number of lines connected at end of 1928.....4236
7. Percentage of increase in number of lines in 1929.....6.95%

II leads to the conclusion that in the rotary system the percentage of machine errors is negligible compared with those made by the subscriber.

The high grade of service now being given by the Swiss Government in Zürich, Basle, and Geneva, is not being obtained as a result of excessive maintenance costs; on the contrary, the cost figures which have been obtained by

the Swiss Government are very low as shown in Table III. In this Table the size of the maintenance personnel for the larger offices is shown, together with the equivalent value expressed in man hours per line per year. It will be noted that the figure for the total personnel, excluding wire chief and main frame work, ranges from 2.8 down to 2.5 man hours per line per year with the single exception of the Mont Blanc office in

Geneva. The personnel in this office has been temporarily increased to 3.1 man hours per line per year in order to handle the additional maintenance work required in connection with modifications and extension work now in progress. When this work is completed, the Swiss Administration expects to reduce the personnel to about 7 men, which will effect a corresponding reduction in the man hours per line per year to a figure of 2.7. It will also be noted in this Table that the overall maintenance figure, including wire chief and main frame work, is very low, ranging from a figure of 3.0 to 3.9 man hours per line per year for the group of offices.

Table IV gives the total maintenance force by months for the full year 1929 for the Mont Blanc rotary full automatic office, Geneva, including the automatic equipment for the Geneva toll board located in the same building. The average total time spent per working line per month in maintaining the central office equipment including the power plant was 13 minutes 41 seconds.

The Chatelaine satellite which served during the year 1929 an average of 287 subscribers is

not permanently attended. It is visited at intervals for testing, for inspection of power plant, which is partially automatic, and for connecting and disconnecting subscribers. The total time spent on this work by months for the year 1929 is shown in Table V. The average time per working line per month was 3 minutes, 54 seconds, including traveling.

The Swiss Government's very satisfactory results with rotary equipment are due primarily to two factors, first, the high efficiency of the Swiss maintenance staff, and second, the sturdiness of the rotary equipment combined with the facilities providing for its control. In maintaining the rotary system in Switzerland as elsewhere, night work is not necessary. All essential testing, repairing, and cleaning is done between the hours of 8:00 A.M. and 12:00 noon, and 2:00 P.M. and 6:00 P.M., or between 1:00 P.M. and 5:00 P.M. in case one hour instead of two is taken for luncheon. In the larger offices one man usually is in attendance from 6:00 P.M. to 10:00 P.M. in connection with the operation of the power plant but between the hours of 10:00 P.M. and 7:00 A.M. the offices are left

TABLE V

MAN HOURS DETAILED
PERIOD: 1929AREA: GENEVA
EXCHANGE: CHATELAINE

MONTH	NUMBER OF MAN HOURS		Number of Lines	NUMBER OF MAN HOURS PER LINE AND PER MONTH		
	On Work	On Travelling		On Work	On Travelling	Total
January.....	19 h 50'	5 h	274	4' 20"	1' 6"	5' 26"
February.....	7 h 10'	1 h	278	1' 33"	13"	1' 46"
March.....	34 h	279	7' 18"	7' 18"
April.....	13 h 50'	2 h	279	2' 58"	35"	3' 23"
May.....	13 h 10'	2 h 20'	282	2' 48"	30"	3' 18"
June.....	18 h 15'	2 h 15'	286	3' 49"	28"	4' 17"
July.....	8 h 20'	1 h 40'	289	1' 44"	21"	2' 5"
August.....	17 h 10'	1 h 40'	290	3' 33"	20"	3' 53"
September.....	25 h	3 h	297	5' 3"	36"	5' 39"
October.....	21 h 30'	1 h 30'	296	4' 21"	18"	4' 39"
November.....	11 h 40'	2 h 15'	296	2' 22"	27"	2' 49"
December.....	11 h 20'	297	2' 17"	2' 17"
Total.....	199 h 15'	22 h 40'	3' 30"	24"	3' 54"
Averages.....	16 h 36'	1 h 53'	287	3' 30"	24"	3' 54"

Number of man hours per line per year..... 41' 39" 4' 44" 46' 23"
 Number of lines equipped..... 300
 Number of lines connected at end 1928..... 272
 Percentage of Increase of number of lines in 1928..... 9.2%

Note: The above maintenance man hours include the maintenance of the equipment as a whole.

unattended except for the services of a watchman.

To make testing during working hours possible, automatic routine test circuits have been developed to a high degree of efficiency. These test circuits pick up the switching circuits in order and test them for all possible failures. The presence of a switchman other than to start the tests is not required. When a failure is found, the automatic test circuit stops and

signals the fault to the attendant. In this way the attendant is enabled to devote his entire time to fault correction, cleaning, and general supervision. Moreover, the routine test circuits are designed to test the switching circuits for more severe conditions than are met with in actual practice so that an incipiently faulty circuit is detected before it actually fails on a connection attempted by a subscriber.

The Selector System of Supervisory Remote Control as Applied to the Great Indian Peninsula Railway

By W. R. DAVIES

Standard Telephones and Cables, Limited

THE Selector System of Supervisory Remote Control, manufactured by Standard Telephones and Cables Ltd., provides a means for controlling and supervising from a control station a number of electrical devices such as oil circuit breakers and contactors located in one or more substations remote from the control point.

For the guidance of the Controller, a Control Diagram is usually supplied (Fig. 1), on which is shown the layout of the apparatus under control with each switch in a position on the diagram relative to its position in the network at the substation. On the diagram, each switch is represented by a small key and lamp box mounting two selector keys and two lamps; one key being required for each of the controlling operations "Close" and "Open," and one lamp being necessary to indicate each of these switch positions.

The selector key (Fig. 2) is a small clockwork impulsing device operated by turning the key handle a quarter of a turn and releasing. The mainspring then rotates a code wheel through a gear train, the speed of rotation being regulated by a simple governor, and the code wheel causes a contact spring riding over its teeth to make and break contact with another contact spring, thus giving the impulses. These impulses are of equal make and break and are sent in three digits, the number of impulses per digit being readily changed by means of adjustable segments which mask certain teeth on the code wheel or prevent the contact springs from closing.

When a selector key is operated, the coded train of impulses originated by it causes a pole changing relay to send battery reversals over two of the three lines connecting the substation with the control point.

Bridged across the lines at the remote stations in series with condensers are impulse receiving instruments known as selectors, which respond to the incoming impulses.

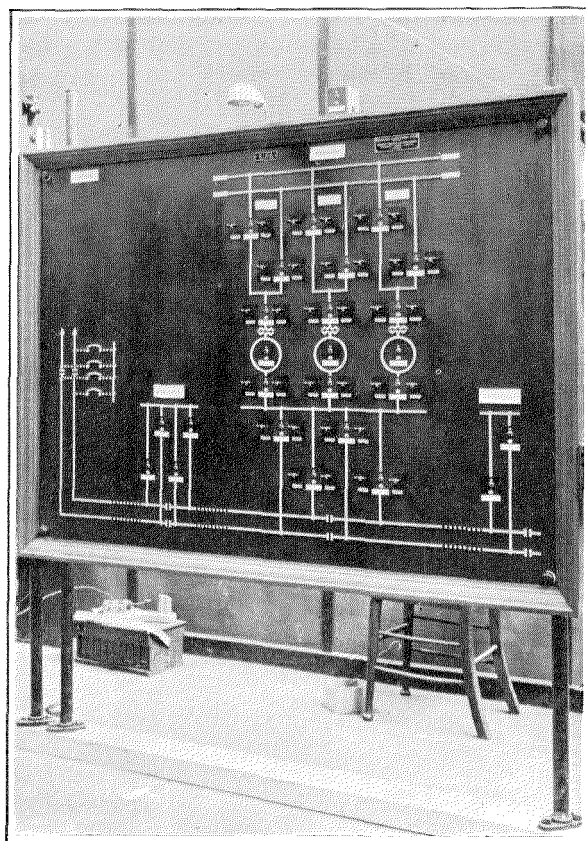

Figure 1—Control Diagram, Kalyan-Vangani System.

The selector (Fig. 3) is essentially a polarised relay, with a centrally pivoted armature capable of responding to the received impulses by vibrating between the poles of the relay at the same speed as that of the impulses.

This vibratory motion is transferred by a system of levers to a pawl which, in turn, rotates a fine-toothed ratchet wheel and a code wheel. The code wheel carries a contact arm which makes contact with a selected one of four fixed contacts to close the desired local circuit. A pause occurs in the impulsing at the end of each digit of the code, and during this pause the stepping pawl is not engaged with the ratchet

wheel and the code wheel is free to return to normal under the action of a restoring spring. To prevent the desired selector code wheel from restoring to normal during these pauses, holding

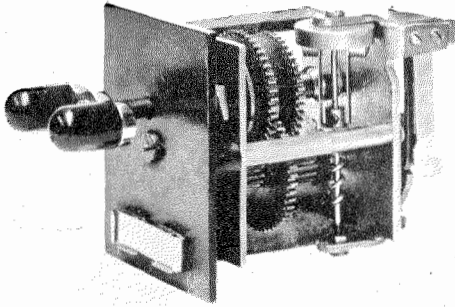

Figure 2—Selector Key.

pins are fitted in the wheel rim which engage with a holding spring, and the positions of the holding pins round the rim determine the code of the selector. A total of seventeen impulses in the three digits is required to select the first fixed contact, nineteen for the second fixed contact, twenty-one for the third and twenty-three for the fourth.

The code wheels of all selectors having a common first digit will be held on their first holding pins, but one selector only is coded to the code

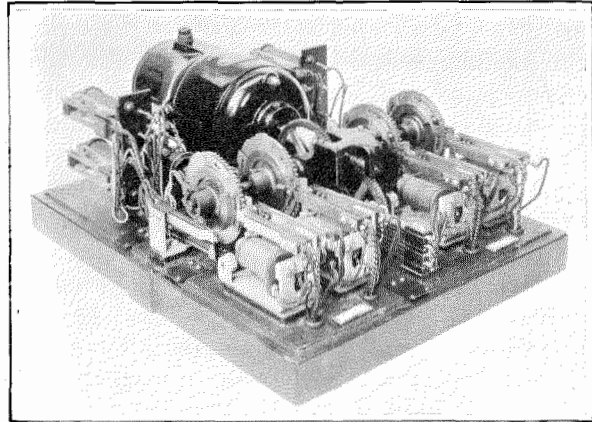

Figure 4—Motor Key Unit.

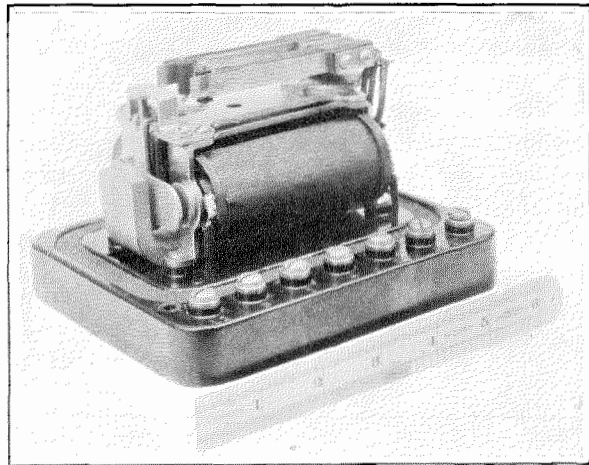

Figure 5—Polarised Relay.

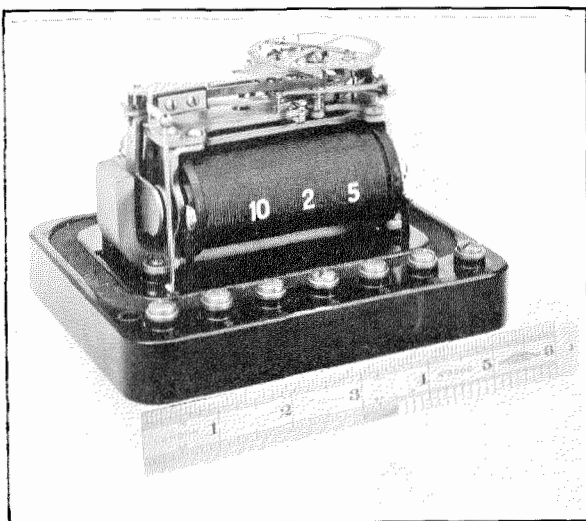

Figure 3—Selector.

of the associated selector key, and this selector alone will be fully impulsed to a position to close a local circuit to carry out the control desired and originated by the controller.

Each selector, having four fixed contacts, is capable of controlling four switching operations such as opening and closing two power switching devices.

The switching devices under control are fitted with auxiliary contacts connected to a motor key unit, and changes in the positions of the devices result in impulses being transmitted from the motor key unit at the substation to the control point.

The motor key unit (Fig. 4) originates impulses similar to those originated by the selector

key, that is, a coded train of three digits, but the mechanism is driven by a small motor and is associated with lockout relays and contacts. A change in the position of a switch causes a motor start relay to energise over two of the pilot lines in series with a relay and battery at the control point. The main shaft of the unit carries four code wheels driven through friction clutches and each code wheel has a complete code on each half of its circumference. The code wheels are prevented from rotating by extensions on the armatures of release magnets, but when the motor start relay is operated, one release magnet is energised to release the code wheel corresponding to the switch, which has changed its position. This code wheel is permitted to revolve and to impulse a pair of contacts over one of the lines already in use and the third line.

When a code wheel has completed a half revolution and has sent its code, the release magnet is de-energised to prevent it from rotating further and the motor is stopped.

Lockout features are provided so that only one code wheel is allowed to rotate at a time no matter how many motor key units or substations there may be on the system and no

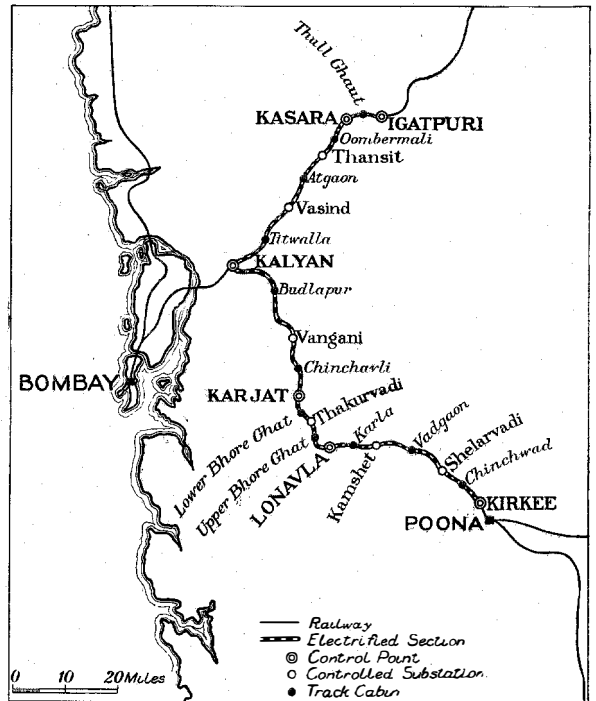

Figure 6—Map of Electrified Section, G. I. P. R.

matter how many switches may have changed simultaneously.

At the control point, the impulses received

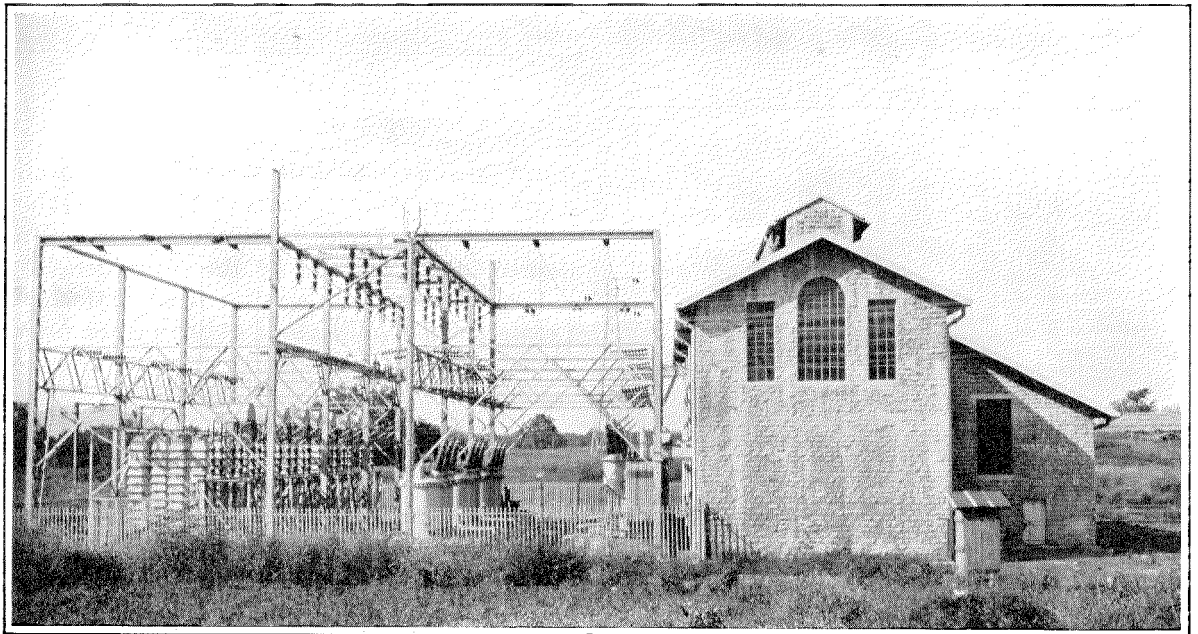

Figure 7—Vangani Substation.

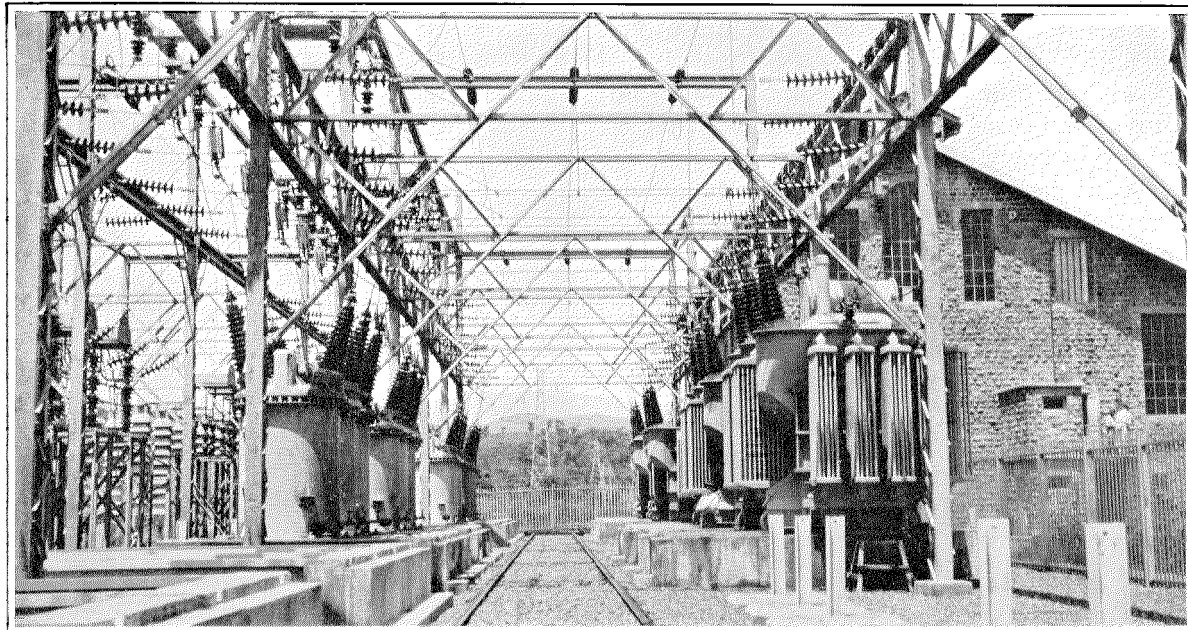

Figure 8—95 KV Outdoor Equipment at Karjat Substation.

from the motor key unit are utilised to cause a selector to step and to complete a circuit for a polarised relay (Fig. 5) which, when operated, will cause the indicating lamps to change; thus if the red lamp was alight to indicate that the switch was closed, a change in the position of the polarised relay will extinguish the red lamp

on one half, the code begins on the top of a tooth so that the impulsing contacts are closed; and, on the other half, the code begins at the root of the tooth when the impulsing contacts are open. By this means the pole changing relay is operated for the last impulse of the last digit in the one case and released for the other; and, since the battery for the polarised relay is fed through contacts on the pole changing relay, the direction of the current through the polarised relay, and hence the direction in which it will be operated, is determined by the half of the motor key code wheel originating the code. This enables one selector used for indication purposes to be associated with four polarised relays for the two-way indication of four power switches.

As previously mentioned, the motor key start relay operates in series with a relay at the control point. The relay at the control point provides a lockout for the control impulses so that should a selector key be operated during the reception of impulses from a substation, the latter impulses are not interfered with or disturbed in any way. In addition, the relay lights a pilot lamp and rings a bell so that the controller has both visual and audible warning of a change

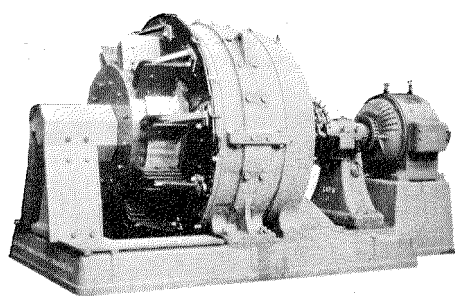

Figure 9—B. T. H. 1250 kw. Rotary Converter.

and light the green one to indicate that the switch is now open, and vice versa.

It has been stated that each code wheel has a complete code on each half of its circumference. These codes are the same in digit value but,

in position of any of the switches under his control.

The total time required for a control to be effected or for an indication to be received is eight seconds.

The greatest number of two-position power devices that can be controlled on a single selector supervisory remote control system is 102.

The system requires a main battery of 124 volts, also a 24-volt battery at the control point and one 24-volt battery at each substation.

It is necessary for the control diagrams to be constructed specially for each system because the apparatus under control varies in almost every case. They comprise an angle-iron frame-

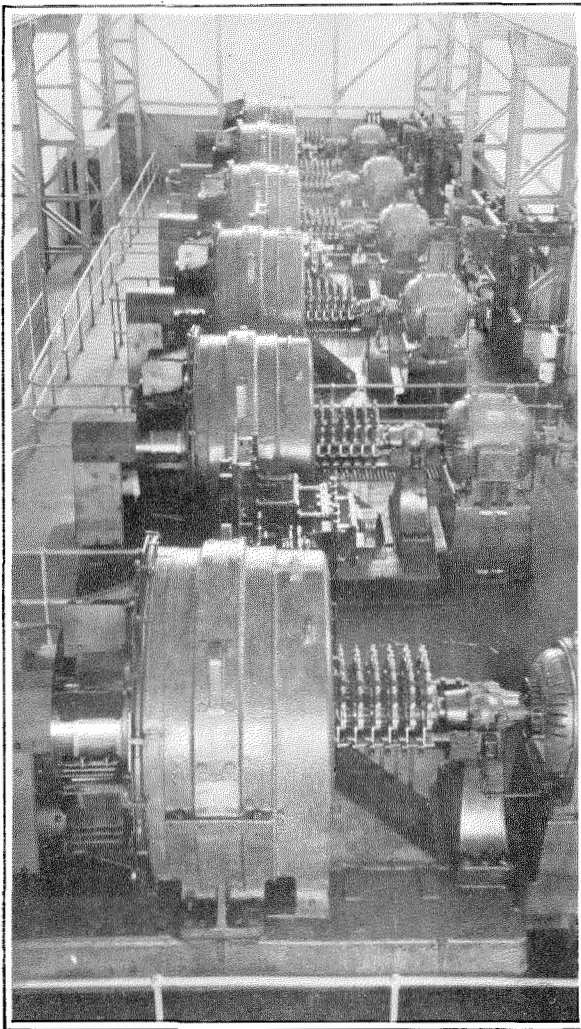

Figure 10—Machine Room, Vangani Substation.

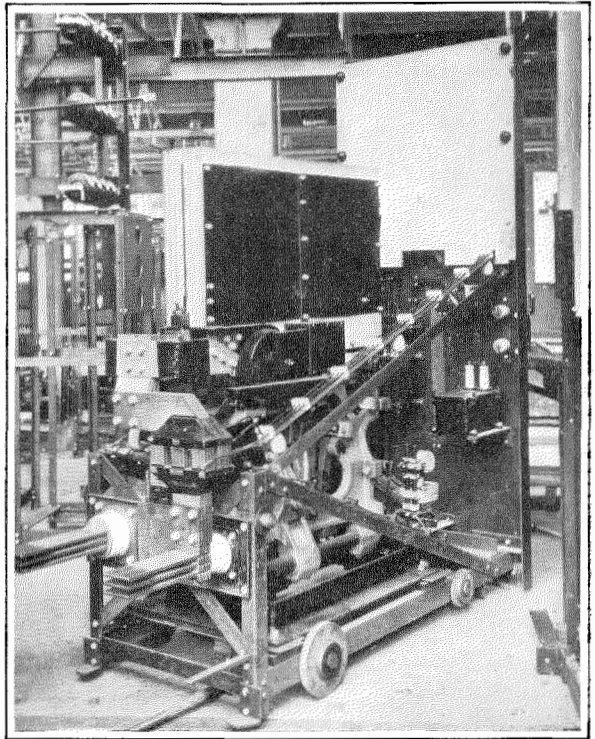

Figure 11—B. T. H. 1500 V., D. C. Truck Type High Speed Circuit Breaker.

work mounting black enamelled brass panels, and the structure is framed with a polished wood moulding (Fig. 1). The layout of the control station is shown on the brass panels by nickel silver strip and, in their correct position in the layout relative to their position in the substation, the controlled switches are simulated by key and lamp boxes, mounting selector keys and indicating lamps, as already explained. The completed diagrams are erected on pipe uprights with back stays.

Panel mounted supervisory control apparatus is employed. Four types of panels are used, namely, the control panel, indication panel, selector panel, and motor key panel. These panels are of slate 30" x 24" x 1½" and are finished with black enamel.

The Control Panel mounts the control and impulsing relays and small circuit breakers required for the control operations, and is located at the control point. One control panel is required per system. The Indication Panel mounts the polarised relays required at the control

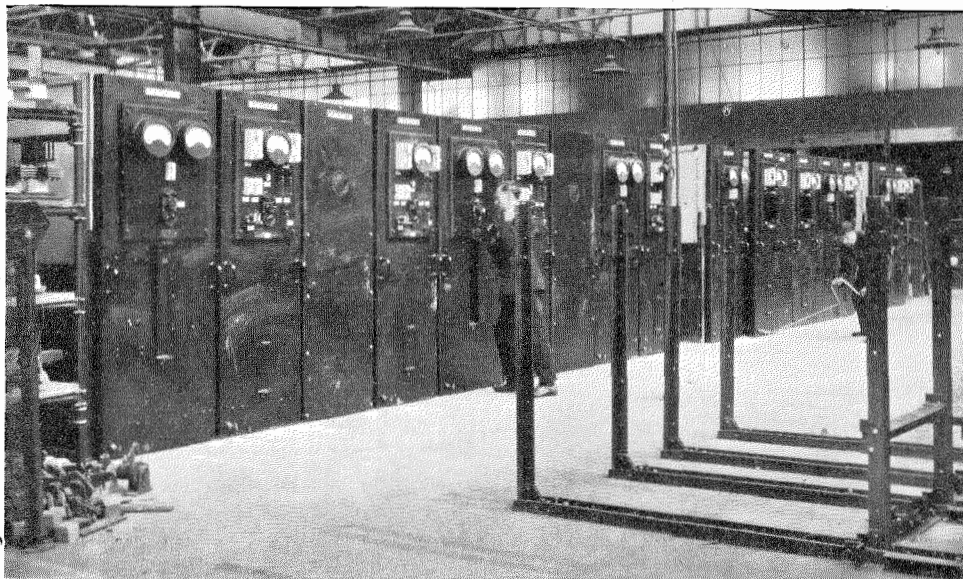

Figure 12—B. T. H. Truck Type Switchgear Units (Front View).

station for effecting changes in indication; and, as their names imply, the selector panel and motor key panel mount the selectors and motor key units, respectively. Selector panels may be located either in the control station to receive the impulses from the substations or in the substations to receive the impulses originated by selector keys on the control diagram. Motor key panels, of course, are always located at the remote substation.

Combinations of the above panels are used to form Apparatus Bays, each bay comprising two panels mounted by panel supports on pipe uprights with back stays. The necessary terminal strips and racks of condensers are also mounted on the pipe uprights and at the back of the panels.

The Selector System of supervisory remote control is particularly well adapted for use in cases where it is desired to control from and indicate at a common control point a large number of switches located in a number of remote points. These conditions exist on the electrification scheme recently undertaken by the Great Indian Peninsula Railway, where the use of the supervisory system has enabled con-

trol from one point of a section of the track larger than would otherwise be possible and has also effected a considerable economy in labour.

The main line electrification of the Great Indian Peninsula Railway, which has been engineered by Messrs. Merz & Partners, was commenced in 1927 and covers two sections, namely, the S. E. Section from Kalyan over the Chats to Kirkee, and the N. E. Section from Kalyan to Igatpuri—a total distance of 129 miles (Fig. 6).

The central power station is located at Kalyan, approximately at the middle of the section electrified, and has a total plant capacity of 40,000 kw. Emanating from Kalyan and running through the length of the electrified section are overhead transmission lines on which the normal pressure at the power station is 95,000 volts, and maximum pressure 110,000 volts.

At distances of about 12 miles are built substations, each containing either two or three rotary converter units which convert the 3-phase A.C. high tension supply down to 1,500 volts D.C. This pressure is applied to the trolley wires, whence it is collected by the pantographs of the locomotives for the traction motors. A small motor generator on the locomotive is used to

obtain a 50-volt supply for the train control and lighting circuits. A typical controlled substation—Vangani—for traction service is shown in Fig. 7, whilst the 95 KV outdoor switchgear and transformers at these sub-stations is illustrated in Fig. 8.

The rotary converter units were manufactured and installed by the British Thomson-Houston Co., Ltd. Figure 9 shows one of these machines, which are rated at 1,250 kw., 750 volts, 600 r.p.m. In the substations, two rotary converters are connected in series to give an output of 2,500 kw. at 1,500 volts D.C., so that a three-unit substation actually has six rotary converters. Such a station is shown in Fig. 10, which illustrates the machine room at Vangani Substation and which is controlled from Kalyan by means of the supervisory remote control system. Any change in the conditions existing at Vangani are indicated on the control diagram at Kalyan, so that, should another unit be run up automatically and put into service due to an increase in the load demand, the controller at Kalyan is informed by the change in indications.

Associated with each rotary converter unit is a double throw-line isolator, a main oil circuit

breaker on the E.H.T. side, a high speed circuit breaker on the D.C. side and a machine temperature warning device. The machine temperature warning device comprises a relay connected to a thermal relay, which operates in case the temperature becomes excessive. The switchgear was constructed by the British Thomson-Houston Co., Ltd. Figure 11 shows one of the 1,500-volt D.C. truck type high speed circuit breakers, and Figure 12, a number of these switchgear units viewed from the front.

The machines feed on to a common bus-bar which is connected through four feeder breakers to the trolley wires. These trolley wires are run in sections between the substations, and the feeder breakers are arranged to permit sectioning or interconnecting the trolley wire supply to enable the maximum use to be made of the track copper conductivity. The feeder breakers are used in conjunction with track sectioning breakers, four of which are placed in each track cabin situated along the track between the substations.

For the purpose of supervisory remote control the electrified section is divided into seven systems, particulars of which are given in the following table:

System Number.	Control Station.	Controlled Substation.	Number of rotary converters in controlled Substation.	Track Cabins Controlled.	Total number of switches controlled.	Total number of switches indicated.
1	Kirkee	Shelarvadi	2	Chinchwad and half of Vadgaon.	14	21
2	Lonavla	Kemshet	2	Half of Vadgaon Karla and half of Upper Bhore Ghat.	16	23
3	Karjat	Thakurvadi	2	Half of Upper Bhore Ghat, Lower Bhore Ghat and half of Chinchavli.	16	23
4	Kalyan	Vangani	3	Half of Chinchavli and Budlapur.	18	26
5	Kalyan	Vasind	3	Titwalla and half of Atgaon.	18	26
6	Kasara	Thansit	2	Half of Atgaon Oombermali and half of Thull Ghat.	16	23
7	Igatpuri	—	—	Half of Thull Ghat.	2	2

Each of the systems is complete in itself and is independent of the other systems. A control diagram is provided in each control station and the controllers are enabled to start up or shut down the rotary converters under their control by closing or opening the associated circuit breakers and oil switches. Indications of the positions of the four switches associated with each rotary converter, the rotary converter temperature indication, the four feeder breakers and the four track sectioning breakers in each track cabin are provided on each control diagram and a further indication is given when the battery motor generator of the substation under control is cut in to charge the station batteries. The track sectioning breakers are fully indicated, that is, for both "close" and "open" positions, whilst certain of the track sectioning cabins have the breakers under supervisory control so that a controller can make the whole of his section dead without having

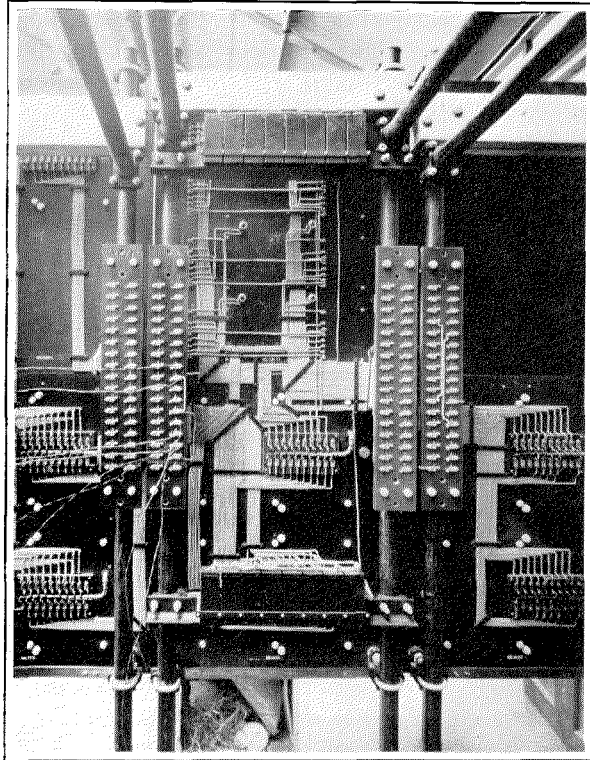

Figure 14—Back View of Apparatus Bay.

to resort to switching operations by the controllers of adjacent sections.

The control diagram illustrated in Fig. 1 is that supplied on the Kalyan-Vangani equipment, and it is typical of those used on the other systems. The diagram shows the complete arrangement of the substation and track cabins controlled. Kalyan, the control point, is represented on the extreme left, then Budlapur Track Cabin, Vangani substation, and finally half of the Chinchavli Track Cabin on the extreme right.

Considering the Vangani portion, it will be seen that it is a three rotary converter station (Figures 1 and 10), the units being represented by the circles of nickel silver strip. The two horizontal strips at the top of the diagram represent the 110,000-volt high tension lines running throughout the electrified section. Simulated connections are made from these lines to two key and lamp boxes for each rotary converter. These key and lamp boxes represent the high tension isolators, and the two selector keys

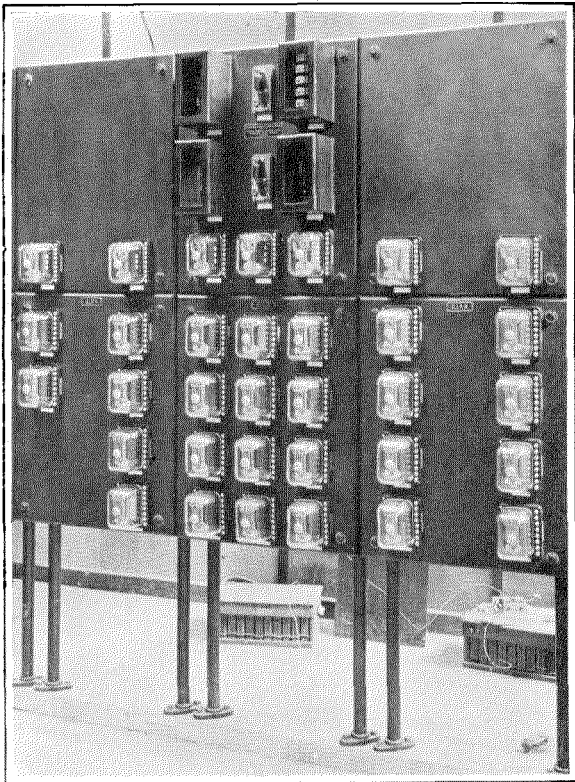

Figure 13—Supervisory Apparatus Bays, Kalyan-Vangani Systems.

and indicating lamps associated with each isolator are clearly shown in the illustration. The control of an isolator is effected by turning the right-hand or left-hand selector key to close or open the isolator, as required.

The high tension lines are fed to the transformer through an oil switch, from the other side of the transformer to the rotary converter, and from the oil circuit breaker and auto control unit to the main bus-bar. Feeder breakers connect the bus-bar to the trolley wires, which are shown by the two horizontal strips running at the bottom of the diagram and throughout its length.

Within the circle representing the rotary converter unit are two indicating lamps. These are used for the machine temperature indication and normally the green lamp is alight. Should the temperature of the machine become excessive, however, an indication is sent from the substation which will extinguish the green lamp and light the red lamp.

Budlapur and half of Chinchavli track cabins are located on either side of Vangani. Only the indication lamps are shown for these track cabins, but extensions to the systems have been made whereby selector keys have been added to enable the track sectioning breakers to be opened.

It will be seen from the diagram that the trolley wire is run in sections between the control station, the track cabins and the substation, and it is apparent that by opening the appropriate feeder breakers in the substation and track sectioning breakers in the track cabins, sections of the trolley wire can be isolated from the supply if necessary.

On the top of the diagram is mounted the pilot lamp, which lights when indication impulses are being transmitted from one of the controlled points, and also in a small lamp box distinctively separated from the rest of the system, the battery motor generator indication.

The ease of operation of the system and its simplicity is apparent when it is realised that it is only necessary to operate the appropriate selector key a quarter of a turn to change the position of any desired switch, and that indication of the selected switch change is received

back at the control point sixteen seconds after the key is released.

The apparatus bays, shown in Fig. 13, comprise the control station apparatus for the Kalyan-Vangani system. The three bays each comprise two panels, the Control Panel being the upper one of the centre bay, and it will be noted that this panel mounts, in addition to the control apparatus, three selectors for the reception of impulses from the substations for indicating purposes. Further selectors are mount-

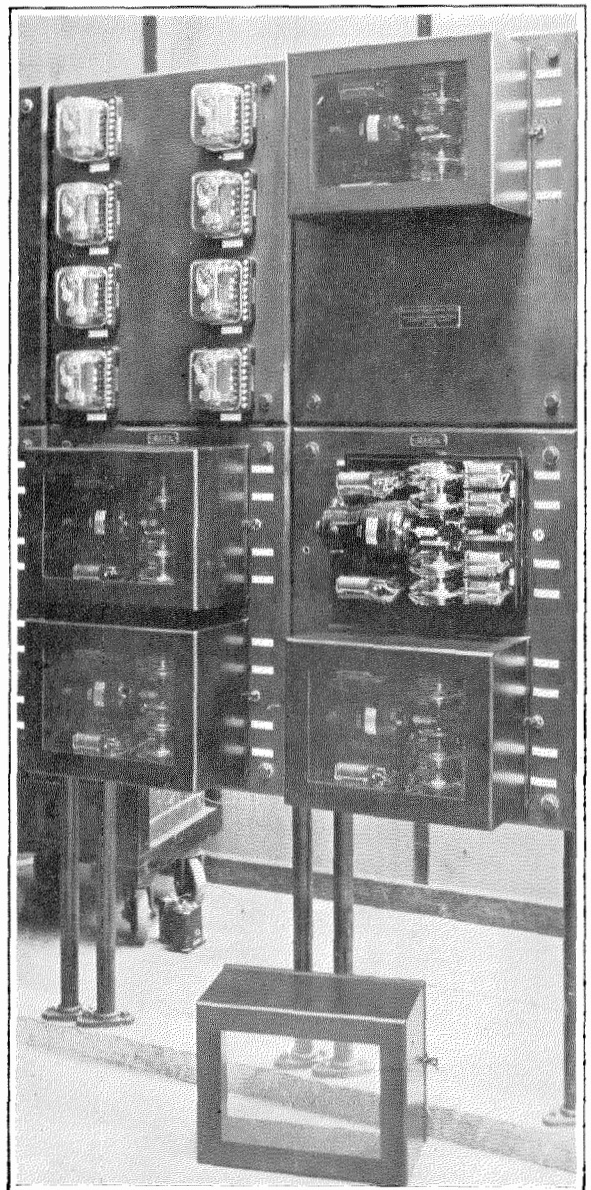

Figure 15—Apparatus Bays at Vangani.

ed on the Selector Panels, which are the two upper panels on the other bays. On each bay, the lower panels are Indication Panels and mount the polarised relays operated by the selectors to effect the necessary changes in indication on the control diagram.

The form of construction used is particularly convenient and of pleasing appearance, for the apparatus is readily accessible for inspection and adjustment, and the arrangement adopted allows the polarised relays to be mounted immediately below the selector with which they are associated and by which they are controlled. It is necessary only to remove the centre clamping screw for the glass covers of the selectors and polarised relays in order to expose the mechanisms, while the dust covers on the control panel have special spring clamping and are of the "pull-off" type. These dust covers give full protection to the control and impulsing relays, since their edges are felt covered and are normally pressed against the panel by the action of the clamping springs.

Connections to the apparatus are made at the back of the panels, each unit being fitted with connecting studs which pass through bushed holes in the panels.

The method of wiring, terminal strips, condenser racks, earth bars and general construction of the apparatus bays is shown in Fig. 14. Triple silk covered, cotton braided, black enamelled, copper wire, Sarco impregnated and

flameproofed is used for wiring the apparatus bays.

The substation equipment illustrated in Fig. 15 is that used for Vangani. Two bays are provided, the left-hand one comprising a Selector Panel in the upper position and a Motor Key Panel mounting two motor key units in the lower position. The right-hand apparatus bay mounts two motor key Panels. Apparatus bays, each comprising one selector panel and one motor key panel similar to those used in the substations, are provided in each Track Cabin.

For the seven systems supplied for the control and indication of the substations and track cabins throughout the electrified section, a total of 38 apparatus bays were supplied, and these in conjunction with the seven control diagrams are controlling 100 power switching devices and indicating 144 such devices.

It has been stated that three pilot lines are required for the Supervisory Remote Control System. These are of 164-lb. cadmium-bronze excepting for the Ghat district, where long tunnels are encountered and insulated cables are used.

The pilot lines are of open construction and are carried on the same structures as the trolley wires. In order to reduce interference from the trolley wires, the pilot lines are transposed continuously to give a complete transposition every eight structures.

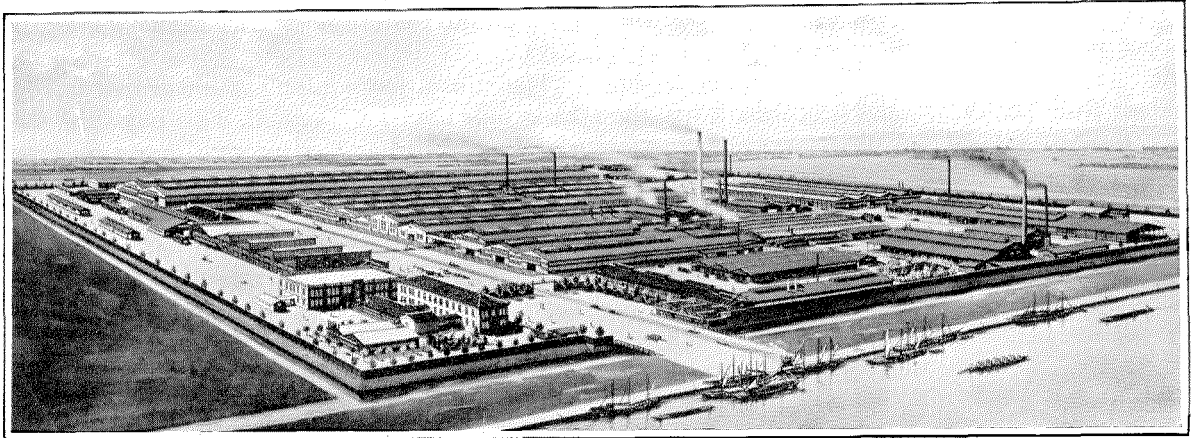

Sumitomo Electric Wire and Cable Works, Limited, Osaka, Japan.

The Second Niihama-Shisakajima Submarine Power Cable

By J. R. PHEAZEY

THE House of Sumitomo, an organization which is in the forefront of modern Japanese industrial and commercial enterprise, had its beginning in Japanese copper mining activities in 1690. The mines and, subsequently, the smelting plants were located at Besshi near the coastal town of Niihama on the island of Shikoku.

In 1899 serious floods occurred in the Besshi area. On this account the smelting operations were moved to the coast near Niihama whilst a new smelting plant was being built on a small island named Shisaka which lies about 23 miles from Besshi and some 13 miles from Niihama. All smelting operations were transferred to Shisaka Island in 1905.

Subsequently, the continuous development of all phases of copper producing led to a hydroelectric power plant being built to serve the Besshi mine area. This in turn induced the desire to transmit power which was being produced economically at Besshi to the smelting plants at Shisakajima and, incidentally, created the problem of providing a sure means by which some 13 miles of the waters of the Inland Sea could be spanned by a power transmission line.

The solution of this problem was entrusted to the Sumitomo Electric Wire and Cable Works, Ltd., one of the manufacturing divisions of the Sumitomo organization. After comprehensive engineering consideration and a considerable amount of experimental work, this company designed and manufactured a 3-core paper insulated, lead covered and wire armoured 11,000 volt submarine cable for the line from Niihama to Shisaka Island. Due mainly to the great difference in the requirements between paper insulated lead sheathed power cable and the more usual low power submarine cable for speech or signal transmission, it was to be expected that some difficulties would have to be overcome before the cable could be put into service. However, all difficulties were cleared and the cable was put into service in November, 1922. At this time it was believed to be the longest existing submarine cable of its type.

In 1929, it became necessary to transmit additional power to Shisakajima and due to the satisfactory performance of the 1922 cable it was decided without hesitation to lay a second similar cable. The order for the 11,000 volt submarine cable for the duplicate line was

placed with Sumitomo Electric Wire and Cable Works, Ltd. in February, 1929, and the cable was manufactured, laid and put into service by September of the same year.

The design for the second cable embodies some interesting improvements. Thus the cable was double lead sheathed because this construction fully assures the complete impermeability of the envelope and, by improving the flexibility of the cable, facilitates handling both during the manufacturing operations and laying. The protecting armour was made to match the service conditions. At the Shisakajima end, where rocky conditions prevail, 2,000 metres of heavily armoured shore end type cable were used; for the balance of the line, the armouring was made about 30 per cent. lighter than that used for the first cable since the sea-floor and conditions at the Niihama landing permitted this economy.

Special attention was directed to minimising damage to the cable and interference with the service which might come from fouling of the cable by ships' anchors. To limit the extent of water penetration in the event of the sheaths being punctured by any such accidents, the cable was plugged at every 500 metres of its

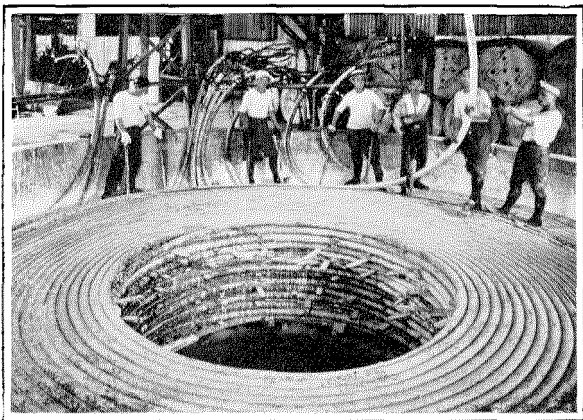

Lengths of 1,000 Metres of Cable Placed in Tanks at the Factory for Testing and Temporary Storage.

length. In addition it was carefully laid in a zig-zag path on the soft sea bottom so that a spare length for repairs is immediately available at all times and any necessity for disturbing

the cable after it has become imbedded in the sea floor, except for a relatively short length on each side of the fault, is removed. This method of laying has the added advantage that only

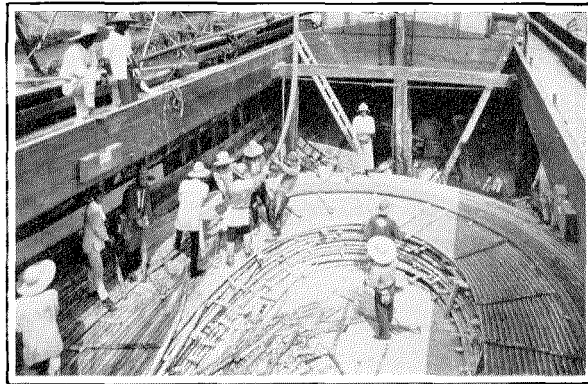

The Hold of the "TAISHO MARU" During the Loading Operations.

one joint is normally required in clearing a fault whereas two joints are necessary whenever a new length is inserted.

The 1929 cable contains four pilot conductors for use in connection with fault indicating apparatus and telephones. The arrangement of these conductors is similar to that used in the earlier cable except for refinements in details. The more usual use of insulated round conductors located in the fillers or wormings between the sector-shaped power conductors was considered and abandoned on account of the increase in the size and cost of the cable which it entailed. An interesting alternative which was examined was the insertion of an insulated pilot conductor in the centre of the cable for a certain distance at both ends of the complete line. The capacity between these end wires and the heavy power conductors would have been utilized to complete one side of the circuit and an earth return would have formed the other side of the circuit. This arrangement would have given only one telephone circuit and a poor standard of fault-indicating service and was therefore rejected. The scheme actually used consists of four copper tapes spirally applied to the cable so as to occupy symmetrical positions in close proximity to the inner cable sheath and to be relatively lightly insulated therefrom. Thus, in

the event of the cable sheath being damaged and punctured, the sea water will quickly penetrate the lighter insulation of these conductors and so through the operation of signals in the

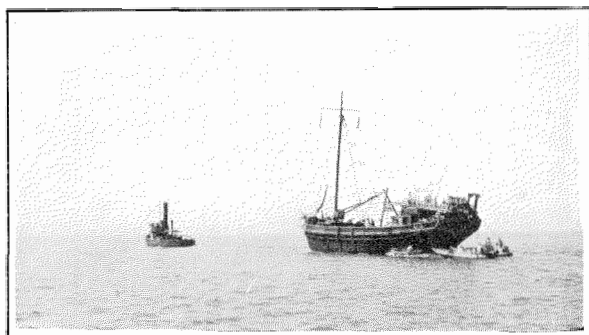

Paying Out Cable in the Inland Sea.

substations, will give a warning of the fault long before the main power conductors are reached or break-down occurs. This feature is also of great value in connection with the check tests which are made repeatedly during the manufacture, laying, and jointing of the cable. In addition to their use for fault indicating, the four pilot conductors provide two telephone circuits through suitable terminal apparatus which is located in the substations. On this account the pitch of the copper tapes is specially adjusted with respect to that of the power-carrying conductors and the conductors diametrically opposite in the cable are used for the telephone services in order to minimise inductive inter-

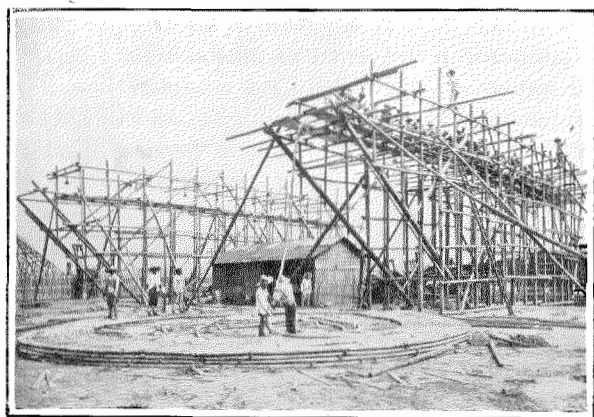

Running the First Section of Cable to the Boat After Jointing at the Factory.

ference. The arrangement and circuits of the fault-indicating apparatus and telephone equipment at the substations is as shown in the accompanying schematic.

Another feature of the cable is the complete absence of joint boxes. For the jointing of factory lengths and also for the joint made at sea, a special joint was developed which permitted the use of lead covering sleeves, approximately of the same diameter as the cable sheath. The use of this construction in cable operating at 11,000 volts is of particular interest. To adequately protect and strengthen the joint mechanically the jointing of the jute bedding, armour wires and jute serving was distributed over a length of some twelve metres and a

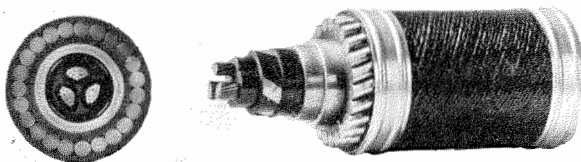

Shore End Cable—Telescoped End and Cross Section.

suitable security binding was applied overall.

The manufacture of the cable was carried out in two parts. For the first section, factory lengths averaging 1,000 metres long were made, tested, and afterwards jointed together to give a length of 11,000 metres. This was shipped to the job and laid from Shisakajima, whilst the second section was being completed at the factory. The second section was 10,000 metres long and was made up in a manner similar to the first. This was sent out to the job in the same boat which had carried the first section and the single sea joint which connected the two sections was made with the first section in the sea and the second section still on board. Subsequently, the second section was laid and landed at Niihama. Inasmuch as it would not have been an economical proposition to engage a regular cable laying vessel for the work of laying this cable, the difficulty was overcome by adapting a small cargo carrier to the service. This adaptation was carried out with no little ingenuity by the Japanese engineers of the Sumitomo Installa-

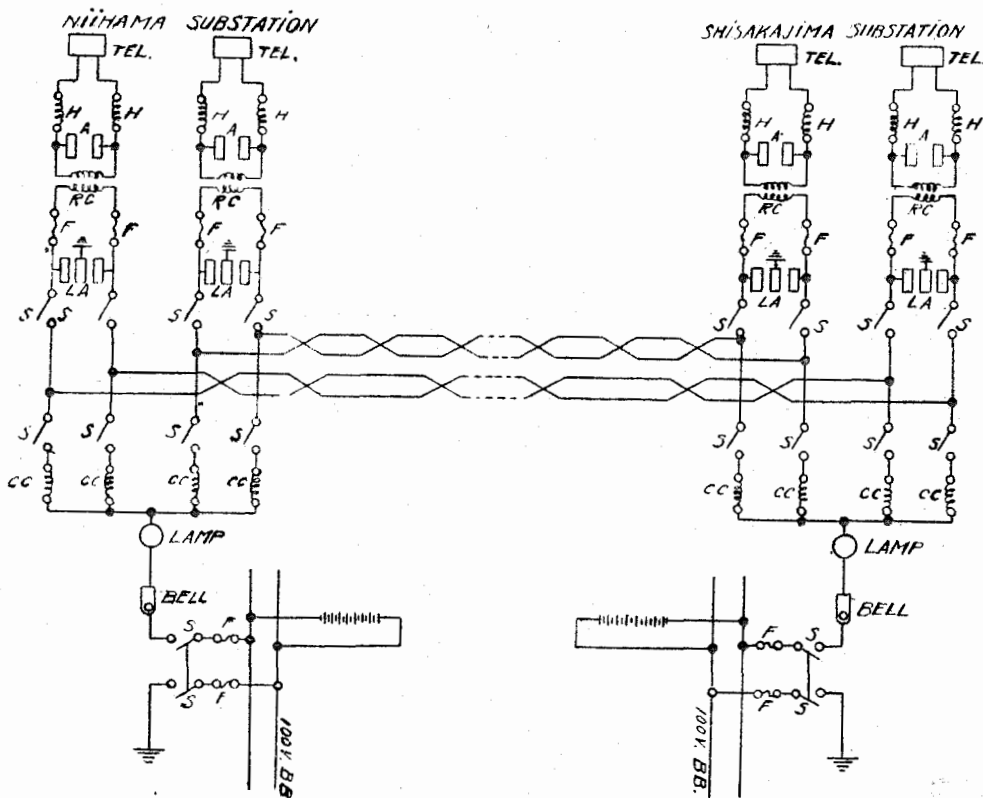

Schematic of Fault-Indicating and Telephone Circuits.

tion Staff and not even the smallest difficulty was experienced in practice.

With the exception of the lead used for the cable sheaths, all the materials used in the manufacture of the Niihama-Shisakajima cable, including the copper, were produced in Japan. The cost of hydro-electric power transmitted from Besshi compared with the estimated cost of power generated at Shisakajima is such that the cost of each of the two complete overhead and submarine power transmission lines from Besshi to Shisakajima can be recovered within a few years. Incidentally, at the time of completion of the second Niihama-Shisakajima contract, the aggregate length of submarine power cables made and laid in Japan by the Sumitomo

Company was more than 56,000 metres. These cables all remain in efficient operation and range from 2,300 volts cable to high tension cable operating at 22,000 volts.

Japan's vigorous progress in modernising the country with almost incredible speed is paralleled in the case of the electrical industry, by Sumitomo Electric Wire and Cable Works, Limited. Even while the second Niihama-Shisakajima cable was being laid, the Sumitomo Company was actively engaged in installing new research, manufacturing, and testing equipment which will still further increase its ability to meet modern requirements for underground, submarine, and power cables.

APPENDIX

1929 Niihama-Shisakajima Cable

GENERAL DESCRIPTION

<i>Type</i>	3 power conductors plus 4 signal conductors. Paper insulated, impregnated, double lead-sheathed and single wire armoured cable for 11,000 volts working pressure.	<i>Pure Lead Sheath</i>	Inner Sheath = 1.9 mm. thick. Outer Sheath = 2.1 mm. thick.
<i>Copper Conductors</i>	Power conductor = one 3.6 mm. dia. wire plus fifteen 1.8 mm. dia. wires laid up into sector-shaped strand. Area = 50 square mm. Signal conductor = tape 8 mm. wide x 0.32 mm. thick.	<i>Single Wire Armour</i>	Shore End Cable = twenty-three 8 mm dia. galvanized steel wires. Sea Cable = twenty-nine 6 mm. dia. galvanized steel wires.
<i>Dielectric Thickness</i>	From core to core = 7 mm. From core to signal conductor = 6.5 mm. From signal conductor to sheath = 1.5 mm.	<i>Diameter Overall</i>	Shore End Cable = approx. 76.3 mm. Sea Cable = approx. 72.3 mm.
		<i>Weight per kilo</i>	Shore End Cable = 21,422 kilograms. Sea Cable = 18,692 kilograms
		<i>Factory Pressure Tests</i>	Each 1,000 metre length between: Cores and Sheath - 25,000 V.A.C. for 10 min. Tapes and Sheath - 1,000 V.A.C. for 10 min. On 11,000 metre and 10,000 metre jointed sections between cores and sheath: 16,500 V.A.C. for 10 minutes.
		<i>Pressure Test after Laying</i>	13,750 V.A.C. for 10 minutes between cores and sheath.

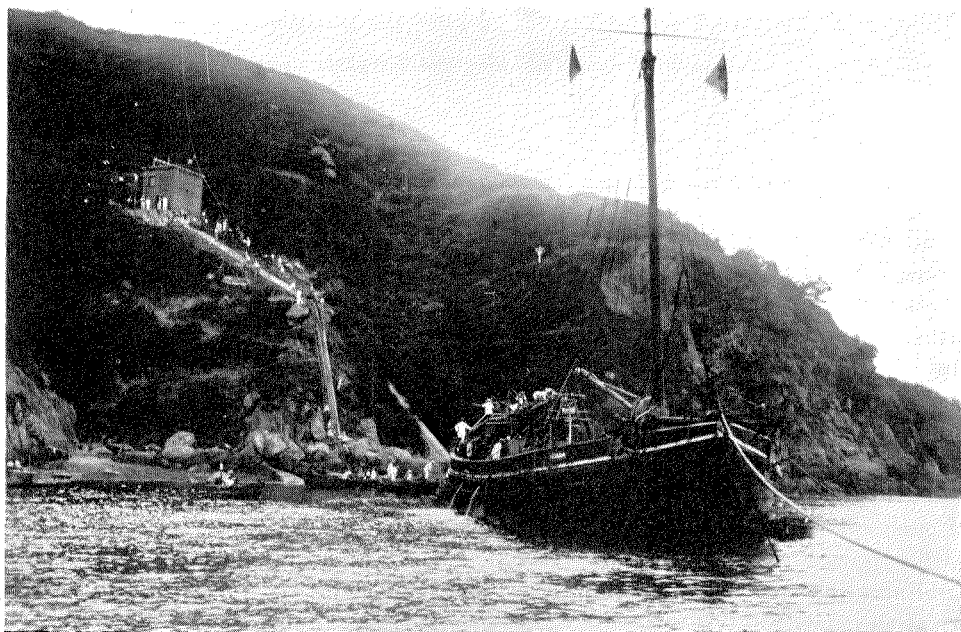

Landing the Shore End Cable at Shisakajima.

New Long Wave Commercial Radio Telephone-Telegraph Transmitters

By D. B. MIRK and S. G. KNIGHT

International Telephone and Telegraph Laboratories, Incorporated

TO meet the demands for up-to-date equipments in the field of long wave commercial radio communication, two new types of medium power transmitters have been developed. These equipments extend over a range from 1 to 3.5 kilowatts antenna power, and they operate on wave-lengths from 600 to 3,600 metres. The fundamental principles governing the design have been reliability, simplicity, flexibility, and economy, consistent with the incorporation of the best features of modern practice.

Design of Equipments

The present day requirements of radio transmitters in general, are far more exacting than those of a few years ago. In the past, the questions of frequency-stability and harmonic radiation were not very deeply considered. Especially was this the case with the lower power commercial types of equipment. At the present time, it is found that, owing to the greater congestion of the ether, more stringent regulations must be made towards the elimination of harmonics and the stabilisation of frequency; and, in designing the equipments, due attention must be paid to these features.

In the case of commercial equipments of this type, it seldom happens that a special building is constructed to suit the requirements of the transmitter. Very often, the equipment may have to be accommodated at an existing site where space is limited. For this reason, the form of the transmitters and associated equipment described in this article have been designed to give as great flexibility and adaptability as possible.

The radio transmitter proper consists of two units mounted side by side and enclosed by suitable panels and doors. The associated power equipment, water cooling system if required, and antenna tuning coil, may be installed in any

convenient positions remote from the transmitter, as indicated in Figure 1, which shows two typical layouts in which ample space has been allowed. If necessary, the equipment may be accommodated in a still smaller space.

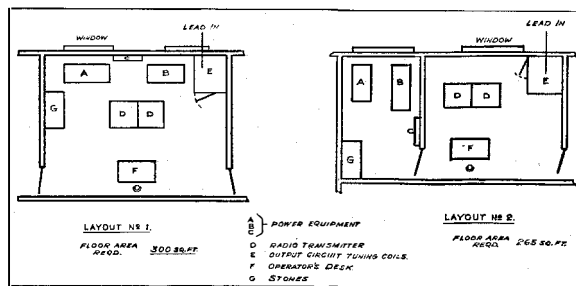

Figure 1—Typical Layouts.

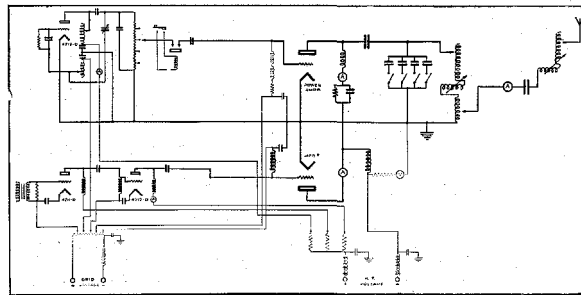

Figure 2—Simplified Circuit Schematic of Transmitters.

The design of the radio frequency circuits is largely dependent on the operating waveband. For commercial transmitters of this type, the allotted wave-lengths fall within a band from 600 to 3,600 metres. To cover such a range of wave-lengths; and also to meet the demand for simple and quick wave-length changing and low cost, it is essential that the number of tuned circuits should be kept to a minimum. In the transmitter under consideration it will be seen from the circuit schematic, Figure 2, that there are only three distinct tuning points.

Although it has been by no means customary in the past to employ a master oscillator on

commercial equipments of this nature, it was considered highly advisable to incorporate it in the present equipments. The use of such a master oscillator, of course, increases the cost of the transmitter in comparison with the cheaper

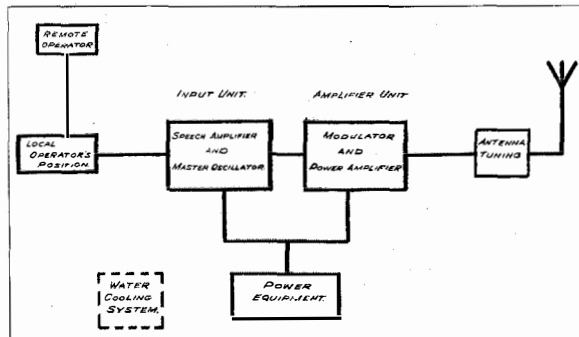

Figure 3—Block Schematic of Equipment.

high-power oscillator type of transmitter, but the resulting advantages of control and frequency stability are such as to justify its inclusion.

To cover the power range of from 1 to 3.5 kw. economically and efficiently, it was considered that two transmitters were necessary; consequently it was decided to design the equipments so that as much apparatus as possible would be common to both. The two transmitters are capable of giving powers up to 1.5 kw. and 3.5 kw., respectively. Figure 4 is a front view of the latter transmitter. It will be seen that the equipment consists of two units hereinafter referred to as the Input Unit and the Amplifier Unit. It was found possible to standardise the Input Unit for both transmitters.

Each equipment consists of the following apparatus shown schematically in Figure 3:

1. Input Unit.
2. Amplifier Unit.
3. Output Circuit and Antenna Tuning Unit.
4. Power Equipment.
5. Local and Remote Control Apparatus.
6. Water Cooling System (if required).

1. Input Unit

This unit, a rear view of which is shown in Figure 5, contains all the apparatus necessary for the amplification of the audio frequency currents and the generation of the radio frequency carrier wave, together with the facilities for keying this carrier for telegraph operation.

The necessary associated supply and smoothing circuits are also contained in this unit, which is approximately 170 cms. high, 80 cms. wide, and 90 cms. deep.

Audio Frequency Circuits.

In designing the speech amplifying circuits, it was assumed that the incoming speech would be received at about zero level, on account of the short lines feeding the transmitter. For this reason the first speech amplifying valve is of the 50 watt type. This valve is choke capacity coupled to a 250 watt valve, which is similarly coupled to the modulator valve. A low frequency oscillator is mounted in the Input Unit.

Radio Frequency Circuit.

Apart from the obvious feature of stability, the fundamental considerations governing the design of the master oscillator were that the output and efficiency should be constant over the wide range of wave-length, and that tuning should be quick and simple, these considerations being allied with low cost. Owing to the difficulty of designing suitable chokes for the wide

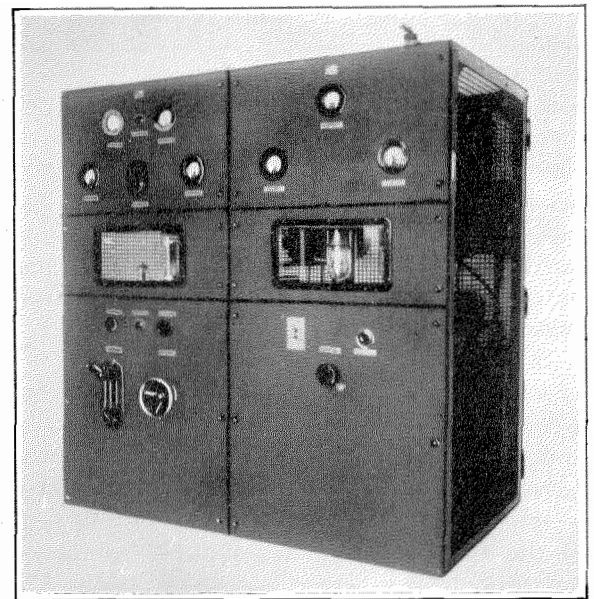

Figure 4—Front View of 2/3.5 kw. Transmitter.

operating wave band, the type of circuit finally adopted was a series fed circuit, Figure 2. This circuit presents the added advantages of simple tuning, which is by means of a variable condenser and a change-over switch on the coil.

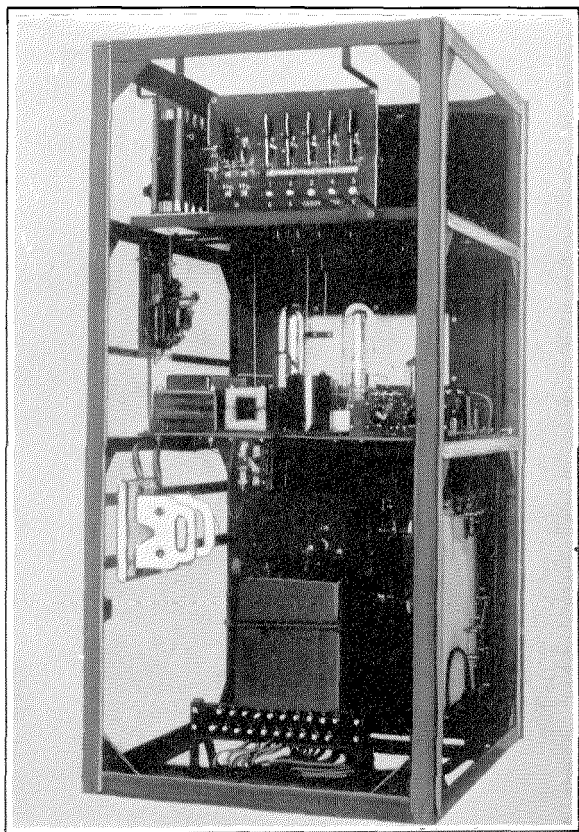

Figure 5—Rear View of Input Unit.

One position of the switch gives a range from 600 to 1,500 metres, and the other position from 1,200 to 3,600 metres. The tuning condenser consists of one variable condenser and five fixed condensers arranged for connection in parallel. Figure 5, at the top of the unit, shows a panel with the five condenser switches and the double pole change-over switch for the coil. A load resistance in the output circuit of the oscillator is used to stabilise the circuit during keying and to present a ready means of changing the radio frequency feed to the following stage of amplification.

Since the utmost simplicity and low cost are demanded from commercial types of equipments, a simple method of keying the equipment was adopted. This is a vacuum tube relay connected directly in the radio frequency output feed from the master oscillator. The vacuum tube relay consists essentially of an evacuated glass tube in which are mounted two iron armatures held apart by stiff helical springs. These

armatures carry the necessary contacts, the leads from which are brought outside the tube through glass seals. The glass tube is protected by a Paxolin tube, the leads being brought out through end caps fitted on this tube. The contacts are operated by a solenoid coil which is slipped over the glass tube so that the centre of the coil is opposite the contacts. When the current from the telegraph key is passed through the solenoid, the contacts are operated. Such a relay, Figure 6, is capable of operating satisfactorily at a rate up to the maximum demanded for hand speeds.

2. Amplifier Unit

The purpose of this unit is to amplify the output from the Input Unit and to transmit it to the output circuit in an efficient manner. The type of valve employed depends on the antenna power required. In the lower power transmitter, that is, up to 1.5 kw., S. S. 1969 Group 1 radiation-cooled valves are used. Figure 7 shows the Amplifier Unit for the 1.5 kw. transmitter. For powers up to 3.5 kw., 4228-A type water-cooled valves are used, as shown in Figure 8.

The two valves in each unit are of the same type, one acting as a high frequency modulated amplifier, and the other as a modulator. The system of modulation adopted is the "Heising" or "Choke Control" type, the two valves being fed from the same high tension D. C. supply

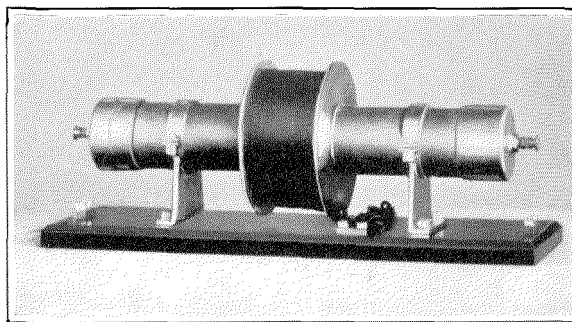

Figure 6—Vacuum Tube Relay.

through a common low-frequency modulation choke. It is well known that, to obtain the best modulation in such a system, the modulator valve must work on a considerably higher

voltage than the modulated amplifier valve, and consequently a resistance has been incorporated which enables this to be accomplished.

The remaining apparatus in the Amplifier Unit consists of such apparatus as is essential for the correct functioning of the equipment, such as filter circuits, meters, etc. Following the practice on all "Standard" radio transmitters, every care is taken to ensure protection for the operating personnel and to safeguard expensive apparatus from abnormal conditions. The radio units, which are self contained, are fitted with safety switches incorporated in the doors, and so arranged that it is impossible to gain access to the equipment until all the dangerous voltages are removed. The valves are protected against anode current overloads by the provision of an overload relay in the negative lead of the anode supply. The water-cooled valves

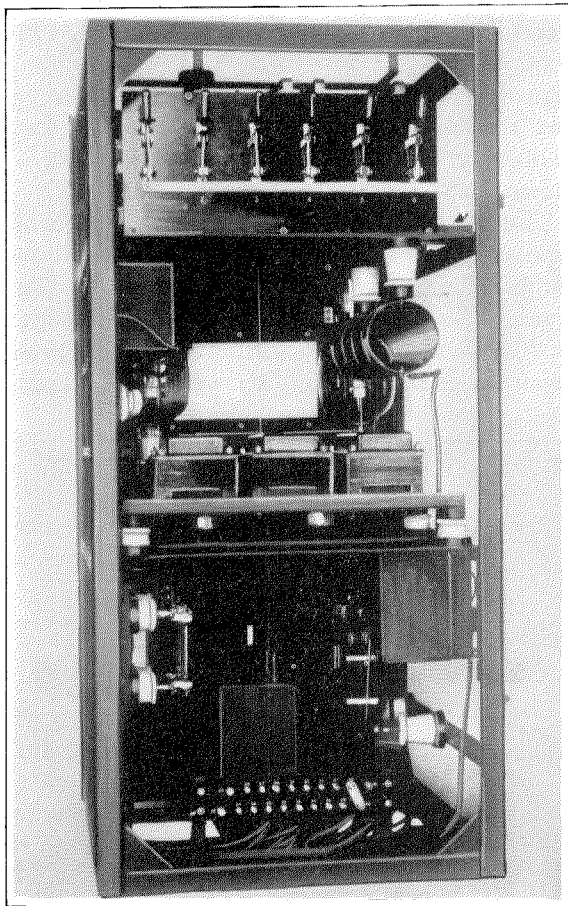

Figure 7—Rear View of Amplifier Unit 1/1.5 kw. Transmitter.

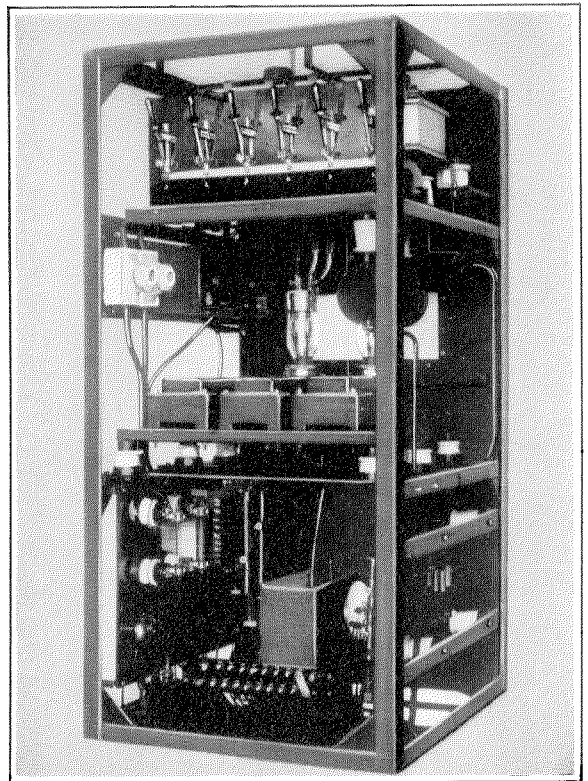

Figure 8—Rear View of Amplifier Unit 2/3.5 kw. Transmitter.

are protected against the failure of the water flow by a special water flow alarm which removes the filament grid and high tension voltages, and by a thermometer which rings a bell when the temperature of the cooling water becomes too high.

3. Output Circuit and Antennae Tuning Unit

In general, the purpose of the output circuit is to transfer efficiently the energy from the last stage of amplification to the antenna, at the same time eliminating the harmonics as far as is economically possible. For equipments of this type, the need for simplicity of tuning and for the production of an equipment of low cost has resulted in the past in the production of equipments whose harmonic radiation has been much larger than is permissible for present day conditions. Consequently an endeavour has been made in this development to produce a transmitter to satisfy the requirements which must obviously be demanded in the near future,

owing to the congestion of the commercial wave band. The type of output circuit adopted is shown in Figure 2. The circuit consists of a tuning condenser and tuning coil, the latter being fitted with tappings for coarse tuning

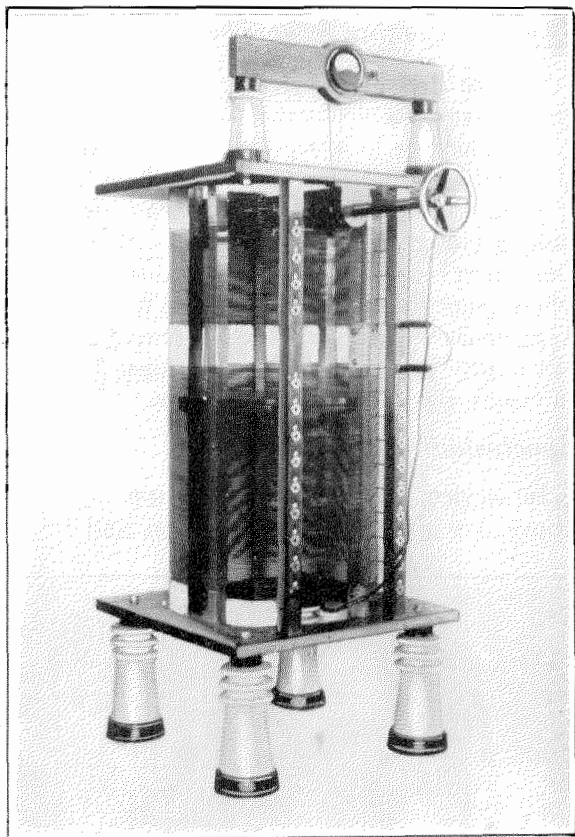

Figure 9—Antenna Tuning Coil.

and a variometer for fine tuning. The tuning condenser comprises four condensers in parallel, the switches for which are mounted at the top of the amplifier unit as shown in Figure 8. The antenna is fed through taps located at the earth-end of the tuning coil. A series condenser may be inserted in the antenna circuit if necessary.

The antenna tuning coil is necessarily large, on account of the high loading required at the longest operating wave-length when using, as is customary, antennae having comparatively low natural wave-length. Furthermore, because of this high loading, there is a high potential

built up along the coil, necessitating large clearances for insulation purposes. In order to provide quick and easy tuning of the antenna circuit a "tapped variometer" type of coil was adopted. This means that the greater part of the coil, the stator, is tapped along its length at suitable intervals to provide coarse steps in tuning, the fine tuning being made by means of a rotor in the field of the stator in the same manner as on the output circuit coil. The taps on the stator are terminated by single socket jacks into which a plug is inserted, such a system providing a quick and certain method of tuning. Figure 9 shows the antenna tuning coil. In general, the output circuit tuning coil is mounted at the base of the antenna coil to form one assembly, but this is not represented in the illustration. This assembly is of Canary wood, which has very low losses at radio frequencies. A minimum of metal is used in the construction, and precautions were taken to reduce corona effects which might occur at the high potential points in the coil.

The unit, with the antenna series condenser, is installed in a position remote from the radio transmitter, such as suits best the lay-out of the equipment in relation to the lead-in of the antenna. An enclosure, with a safety device on the gate, surrounds the whole tuning unit.

4. The Power Equipment

The power supply for this type of transmitter depends entirely on local conditions, and may be extremely variable in nature. In some cases, where an electrical mains supply is not available, it is necessary to provide a prime mover such as a petrol engine; in other cases, a combination of electrical mains supply with a petrol engine as stand-by is demanded. These possibilities indicate the desirability of flexibility in the design of starting and control apparatus.

For the supply of power to the radio transmitter, separate generators are provided for filament, grid, and plate supply, these generators being progressively excited. This feature precludes the possibility of applying the various voltages in the wrong sequence. The control of the voltage of the generators is at the radio transmitter where facilities are provided for measuring and adjusting the voltages, field

rheostats with their respective voltmeters for the filament and grid machine being mounted on the Input Unit front panel, while the field rheostat for the anode machine is mounted on the Amplifier Unit front panel, as also is the anode voltmeter.

The power equipment includes on the input panel a main switch and starter for the motor generator. Switches are also provided for disconnecting the output of the machines from the radio transmitter. To start up the radio transmitter, the main switch is closed and the motor starters are operated. When the machines are up to speed, the field rheostat for the filament and grid machines are adjusted to give the normal voltage. The high tension anode voltage is applied by means of an "on" push button which, when pressed, operates a contactor, the contacts of which close the field circuit of the anode machine. This contactor derives its operating current from the filament machine. When the contactor is operated, the anode voltage is built up to normal by means of the field rheostat. To remove the anode voltage, an "off" button is pressed, this action opening the operating circuit of the contactor.

5. Local and Remote Control

To provide for the various requirements which might be demanded for these equipments, it should be possible to give facilities for the transmission and control of telephony, modulated continuous wave telegraphy (C. W.) and unmodulated continuous wave telegraphy from the transmitter proper, or from a number of remote points. This service necessitates the provision at each control point of a microphone, telegraph key, and liaison telephone, the latter being used to communicate with the Master Control Position, that is, the transmitter position. At the latter position, the operator has to see that the transmitter is properly arranged for the kind of transmission demanded from the remote point.

In addition to the arrangements for transmission enumerated above, there should be available apparatus for monitoring at each point. This is arranged by feeding a loud speaking receiver at each remote point from a central

radio receiver located at the Master Control Position.

The above facilities are given by means of small switching panels fitted with jacks and plugs, of the type shown in Figure 10, for inter-connection such that it is impossible for two remote points to operate simultaneously.

6. Water Cooling System

The method by which the circulating water for the water-cooled valves is provided, again depends on the local conditions. Since the flow of water required is quite low, the water system is comparatively simple and cheap. In most cases a closed circulating system with radiator and pump is all that is required; in installations where plenty of water is available it is possible to dispense with this cooling system altogether, but in any case due precautions must be taken to ensure the correct flow of water.

Conclusion

In service, the type of transmitter described above has given every satisfaction and fulfills

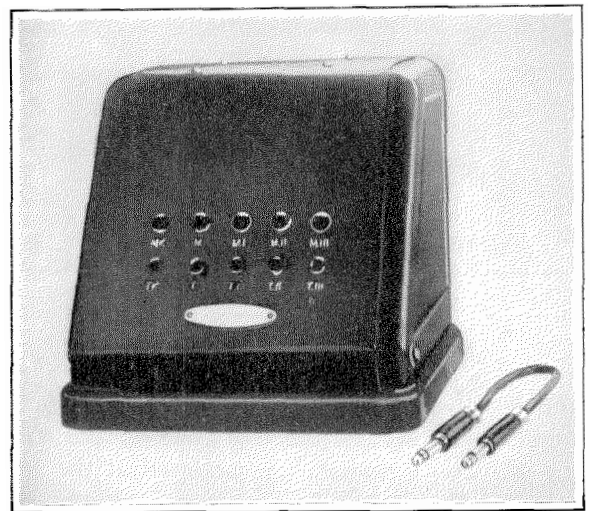

Figure 10—Switching Panel.

amply the requirements specified. The quality of the transmission is very good, the overall efficiency is high, and the operation is exceedingly simple and at the same time safe. Furthermore, it is possible to change from any wave-length to any other wave-length in the band in one or two minutes.

The need for equipments of this type is evi-

denced by the demand for these transmitters, which have already been supplied for military point-to-point communication, and for ground stations for aircraft communication. They are

also suitable for commercial communication and for marine communication, and can be used after minor alterations to the mechanical structure for installation in ships.

Visit of Signor Mussolini to Milan

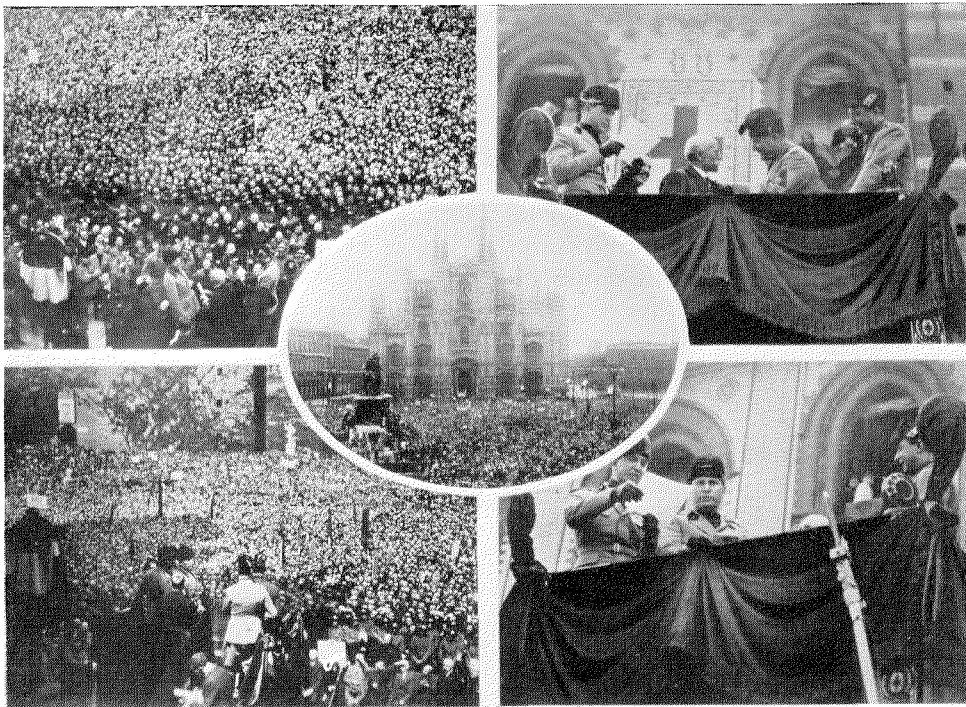

Centre—Demonstration at the Piazza del Duomo. Upper left—The crowd at Castle Sforzesco. Lower left—Another view of the crowd at Castle Sforzesco. Upper right—Signor Mussolini at Castle Sforzesco conferring a medal of merit on a workman with over 60 years of continuous service. Lower right—Signor Mussolini is seen listening to the opening speech. During the various ceremonies, the Public Address System installed by Standard Elettrica Italiana was much in evidence.

The New Standard Echo Suppressor

By W. F. MARRIAGE, B.Sc., A.M.I.E.E.

International Standard Electric Corporation

P. R. THOMAS, B.Sc., A.M.I.E.E., and K. G. HODGSON, B.A.

International Telephone and Telegraph Laboratories, Inc.

Introduction

THE International Telephone and Telegraph Laboratories have recently developed a new type of valve echo suppressor which has been standardized by the International Standard Electric Corporation and which operates entirely without moving parts and is therefore very reliable and easy to maintain. It employs a novel device called a "limiter," such that the output voltage is constant and independent of the input voltage between the levels normally encountered on present day telephone circuits. Before describing the apparatus in detail it is desirable to review the current practice on long distance circuits in order to formulate requirements for the ideal suppressor.

Cause of Echoes on 4-Wire Circuits

The normal arrangement of a 4-wire circuit is shown diagrammatically in Figure 1. At each end of the circuit the E-W and W-E paths are joined by means of a balanced terminating set to a single 2-wire line. In order to maintain a high value of loss between the output of, say, the W-E circuit and the input of the E-W circuit it is necessary that the balance between the 2-wire line and its network be extremely good.

When the 4-wire circuit is extended for a considerable distance by means of a cable or open-wire circuit it is possible to obtain a network closely simulating the impedance-frequency characteristic of the extension circuit. In general, however, a 4-wire circuit is extended only to a local subscriber or through a short junction circuit, and under these circumstances it is not possible to adjust the network to suit all the various lines to which the circuit may be connected. Consequently, a compromise network, which gives only an approximate balance, is

used. It follows, therefore, that the loss from the receiving side to the transmitting side of the 4-wire circuit will vary, depending upon the 2-wire line to which it is connected. Under these conditions, speech currents from a talker at the W end of the circuit on reaching the E termination will be transmitted across the terminating

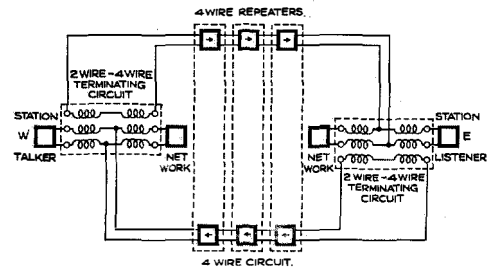

Figure 1—Skeleton Diagram of a Normal 4-wire Circuit.

set with a certain loss and will return on the E-W line to the talker, the level at which they reach the talker depending on the equivalent of the circuit and the balance of the distant, i. e., E end, terminating set. Since a long 4-wire circuit has a finite transmission time, it follows that the reflected current or "echo" will reach the talker after a definite time interval. Further, if the balance at the terminating set at the W end of the circuit is also not perfect, then the echo currents returning on the E-W path will be transmitted to the W-E path and so reach the listener at a definite time interval after he receives the original sound. Thus there are obtained echo conditions for both talker and listener, which impair the quality of the circuit. The echoes generated as described above are called the 1st Talker and 1st Listener echoes respectively, but it will be clear that other echoes of 2, 3, 4, etc. times the time delay will also be generated but will be of progressively decreasing intensity.¹ It is found in practice that

¹A. B. Clark and R. C. Mathes, "Echo Suppressors for Long Telephone Circuits," *Electrical Communication*, July, 1925.

the interfering effect of this echo increases with the time delay between speech and echo. Figure 2 gives an indication of what time delay can be tolerated for echoes with circuits of various equivalents.

Table I shows the maximum length of circuit obtainable with and without the use of echo suppressors. In the case of medium heavy loaded circuits it will be noted that no great gain in circuit length is obtained by using echo suppressors. This is due to the fact that the circuit length with this type of loading is not limited by the effect of echoes but by transient phenomena. In all cases, however, the maximum length of circuit obtainable when echo suppressors are used is theoretically much longer than that shown in the table, but transients limit the length of the circuit long before the above theoretical figures are reached. The figures given in the last column are therefore the limiting length of circuit due to transients.

Echo suppressors may also be applied to circuits made up of both 2 and 4-wire links. In such a case it is preferable in general to locate the suppressor at some suitable point in the 4-wire section depending upon the make-up of the circuit.

Echo suppressors are also widely used in the terminating equipment for radio links.

Operation of Echo Suppressors

The function of an "echo suppressor" is to block one side of the 4-wire circuit when speech is being transmitted on the other side.

At first sight it would seem that a suppressor would be equally effective regardless of its position on the 4-wire circuit. That this is not the case is due to the following considerations. If the echo suppressor be placed at the end of the circuit, the transmission time over the echo path between the input of the suppressor and the point at which blocking is effected approaches zero and the operation of the suppressor must be instantaneous to be effective. This is an impossible condition to obtain in practice, and in addition a minimum limit to the operating time is set in some cases by the disturbing effect on the circuit of the operation of the suppressor. It follows, therefore, that the transmission time of the echo path from the suppressor input to the blocking point must not be less than the operating time of the suppressor. This condition covers the suppression of the initial part of the speech echo. Similarly, consideration of the "trailing" part of the speech shows that the releasing or "hangover" time of the suppressor must not be less than the time of transmission of the echo path.

The above remarks relate to a suppressor which operates on speech in one direction. In practice it is necessary, of course, to provide two identical units which operate respectively on speech in the two directions. The possibility of false operation of a suppressor on echo currents may be avoided by arranging that each unit shall operate to disable the other unit as well as the transmission line. This object is most conveniently performed in the normal case by locating the blocking device at a point which

TABLE I.

Loading System	Diameter of conductors in mm.	Type of Circuit	Nominal Impedance in ohms		Nominal cut-off Frequency in p.p.s.		Transmission Velocity per second		Attenuation at 800 periods per second				Maximum length of Circuit without Echo Suppressors				Maximum length of Circuit with Echo Suppressors			
			790 470	5,800 6,000	20,500 21,000	33,000 34,000	Miles Km.	Mile Km.	Decibels per		Népers per		2-wire		4-wire		2-wire		4-wire	
									Mile	Km.	Mile	Km.	Miles	Km.	Miles	Km.	Miles	Km.		
H-44-25.....	0.9..	Side Phant	790 470	5,800 6,000	20,500 21,000	33,000 34,000	0.50 0.43	0.31 0.27	0.058 0.049	0.036 0.030	800 800	1,300 1,300	3,750 5,000	6,000 8,000		
H-44-25.....	1.3..	Side Phant	790 470	5,800 6,000	20,500 21,000	33,000 34,000	0.26 0.22	0.16 0.13	0.029 0.025	0.018 0.016	750 750	1,200 1,200	3,750 5,000	6,000 8,000		
H-177-63.....	0.9..	Side Phant	1,590 740	2,900 3,600	10,500 13,000	17,000 21,000	0.28 0.29	0.17 0.18	0.032 0.034	0.020 0.021	400 500	650 800	450 550	750 900	500 500	800 800	500 1,500	800 2,400		
H-177-63.....	1.3..	Side Phant	1,590 740	2,900 3,600	10,500 13,000	17,000 21,000	0.16 0.10	0.10 0.10	0.018 0.019	0.011 0.012	400 500	650 800	500 500	800 800		

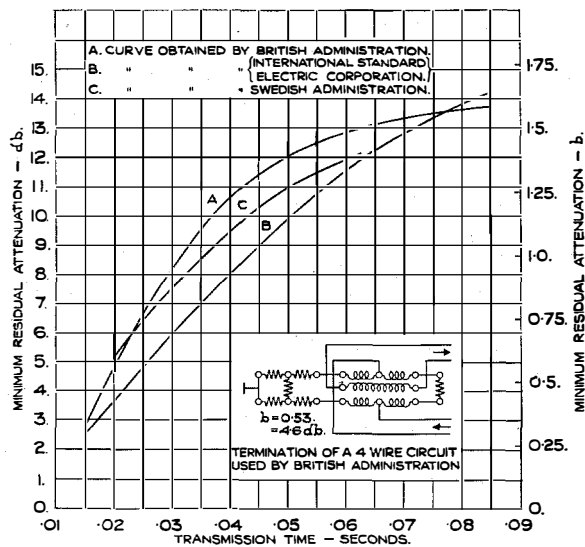

Figure 2—Relation of Time-delay to Attenuation.

precedes the input of the suppressor in the direction of transmission of the circuit.

Operating Requirements

The operating requirements of an ideal echo suppressor may now be stated as follows:

1. The suppressor shall operate when speech is transmitted over one side of the 4-wire circuit and shall prevent the transmission of speech echoes on the other side of the circuit.
2. The "pick-up" time, i.e., the time interval between the arrival of speech at the suppressor and the disabling of the return half of the circuit shall be small, so that the echo suppressor may operate on speech impulses of short duration.
3. The "hangover" time, i.e., the time interval between the cessation of speech at the suppressor and the restoration of the return half of the circuit to normal shall be long enough to keep the return path disabled until the echo originating at the most distant point on any particular circuit has reached the point in the circuit at which disabling is effected. The hangover time should be adjustable to suit circuit conditions.
4. The hangover time should be substantially independent of the speech input level to the suppressor in order that the return side of the circuit may be restored to normal as soon as possible after the last echo has reached the blocking point.
5. The sensitivity of the suppressor should fall rapidly below the minimum level at which operation is required, in order to reduce the risk of operation on line noise. The sensitivity should therefore be variable to provide for the different levels which may occur on the various circuits to which the suppressor may be connected.

The characteristic of the average transmitter

is such as to accentuate the frequencies between 800 and 1,200 p.p.s. rather than the low frequencies which tend to be predominant in speech. Since a large proportion of the noise usually occurring on telephone circuits is of low frequency, an advantage in discriminating between speech and noise can be obtained by broadly tuning the suppressor to about 900 p.p.s. so that the sensitivity falls rapidly below 800 p.p.s. and above 1,200 p.p.s.

Two types of echo suppressor have been used (a) the relay type and (b) the valve or grid jamming type.

The Relay Type Echo Suppressor

The relay type consists of an amplifier-rectifier which is bridged across one side of the circuit, rectifying the speech currents, and operating a relay which short circuits the return side of the circuit. The relay or relay train is designed to be slow releasing in order to cover requirement No. 3. The normal equipment comprises two amplifier-rectifiers each of which

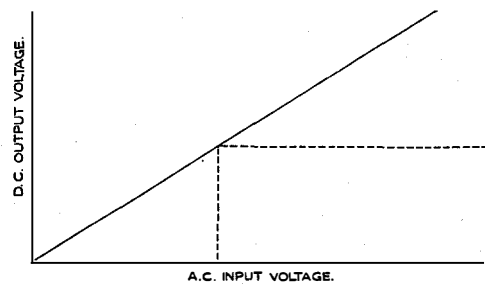

Figure 3—Relation of Input Voltage to Output Voltage.

operates from one side of the circuit and applies a short circuit to the other side.

The Valve Type Echo Suppressor

The valve type echo suppressor differs from the relay type in the method of disabling the return circuit. It employs no moving parts, the output of the amplifier rectifier being used to apply a large negative bias to one of the valves of the repeater on the return half of the circuit so that transmission is effectively prevented by reducing the plate current of that valve to zero.

In order to obtain the necessary voltage for biasing the grid of the repeater valve, the out-

put of the rectifier which is usually connected to operate as a diode is applied to a high resistance in parallel with a condenser, across which the biasing voltage is built up. When

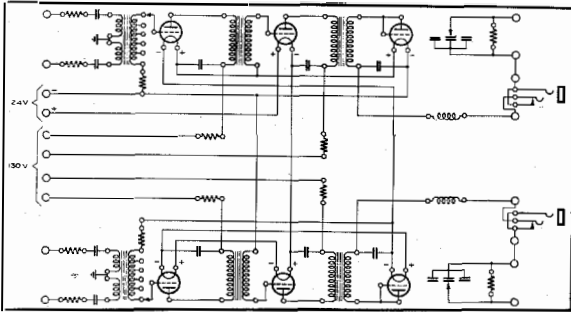

Figure 4—Diagram of Grid-jamming (valve type) Echo Suppressor.

the condenser is charged up, the voltage does not fall to zero immediately on the cessation of speech; the condenser discharges gradually through the resistance and the time taken for the voltage to fall to a nominal value depends on the values of condenser and resistance and the initial voltage to which they are charged.

The relay type of suppressor satisfactorily fulfills all the operating requirements specified above, but has the disadvantage that adjustment of the relays complicates the maintenance problem. The relays concerned are generally of a high efficiency type with which repeater station staffs are not familiar, and since the hangover time depends to some extent on relay adjustment, some form of relay timing panel must be provided for testing. Further, in some cases relay type echo suppressors require a grid battery of the order of 100 volts in addition to the normal battery supplies.

The operation of the valve type suppressor involves but little maintenance. Depending, as it does, on the constancy and stability of fixed circuit elements, routine testing is reduced to checking the operation of valves by normal methods. Even when initially setting up circuits, the only adjustments required are the sensitivity adjustment by means of tapped transformers and the setting of hangover time to a standard calibration by adjustment of resistances or condensers. The operating characteristics of this type in general are, however, not so satisfactory. In particular, suppressors designed hitherto have failed in most cases to

meet requirements 4 and 5. The chief reason for this defect is that an amplifier-rectifier in which the output resistance is large compared with the internal impedance of the diode rectifier has a characteristic as shown by the solid curve of Figure 3, the D. C. output voltage being proportional to the A. C. input voltage. Since the hangover time depends on the output voltage, requirement No. 4 is not satisfied. Further, there is no definite cut-off point and biasing voltages are likely to be generated as the result of line noise. Improvement can be effected in this respect by applying a negative bias to the diode rectifier, but since this merely shifts the curve of Figure 3 to the right, and does not increase the initial slope, this improvement is gained at the expense of sensitivity. The ideal curve to meet these requirements is shown dotted in Figure 3. As will be explained later, the new type of suppressor gives a close approximation to this ideal curve.

The New Echo Suppressor

The development of the new type of echo suppressor is the result of an attempt to combine the desirable operating characteristics of the relay type with the simplicity of mainte-

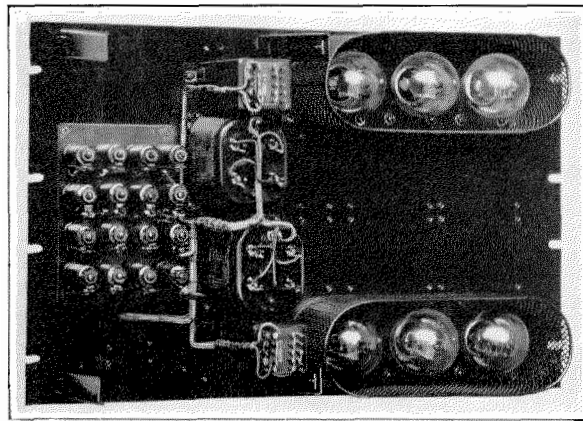

Figure 5—Front View of Echo Suppressor with Cover Removed.

nance of the valve type. That this attempt has met with a large measure of success is clear from consideration of the circuit and its performance.

Circuit Description

The diagram of a complete 2-way echo suppressor is shown in Figure 4, while Figures 5

and 6 show the front and back views of the experimental model.

Discrimination against operation by noise currents is obtained by tuning the input trans-

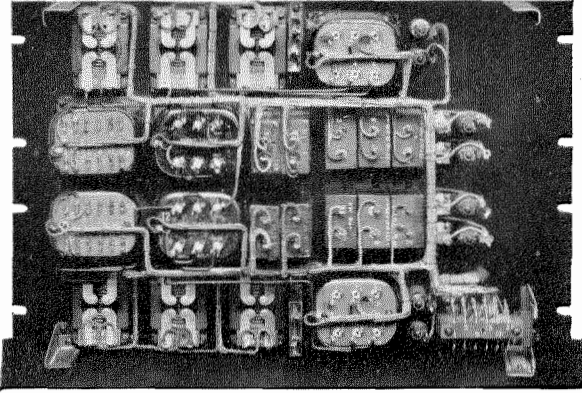

Figure 6—Back View of Echo Suppressor with Covers Removed.

former to approximately 900 p.p.s. by series condensers and by inserting series resistances. The latter flatten the tuning, thus avoiding a large peak at the resonant frequency, and also ensure that the input impedance is high compared with that of the line, so that there is no appreciable loss due to bridging the suppressor across the transmission circuit.

The amplifier has two stages, the input transformer to the first stage being tapped to provide a sensitivity adjustment. The second stage is arranged to act as a limiter and is followed by a diode rectifier, the rectified current, after smoothing, being applied to the condenser-resistance output circuit.

The operation of the limiter is as follows:

The valve is biased to a point on the lower bend of its characteristic, and a high resistance is placed in series with the transformer winding in its plate circuit. As the speech input rises, the plate current is increased, and the drop across the high resistance reduces the effective plate voltage and therefore the gain of the valve. The characteristic has been adjusted to the desired shape by varying the circuit elements and the grid bias on the limiter valve. It is worthy of note that the latter has a profound effect on the cut-off level, i. e., the input level below which no appreciable output is obtained, and on the steepness of the initial part of the characteristic. This feature has enabled a very

close approximation to the ideal characteristic to be obtained, a typical curve being shown in Figure 7.

Since the valve type echo suppressor operates by virtue of reducing the plate current of a repeater valve, a click is apt to be produced on the circuit if the time of operation of the suppressor is sufficiently small. This click may be expected to be of about the same intensity with any type of repeater valve; for, the smaller the normal plate current, the higher the inductance of the associated transformer winding. Hence, the suppression should be performed at a point on the circuit where the normal speech level is as high as possible, i. e., on the last valve of a repeater. This contention is borne out in practice as suppression on the last valve is practically inaudible with a pick-up time of 10 milliseconds, whereas suppression on the first valve is disturbing even with a pick-up time of 20 milliseconds.

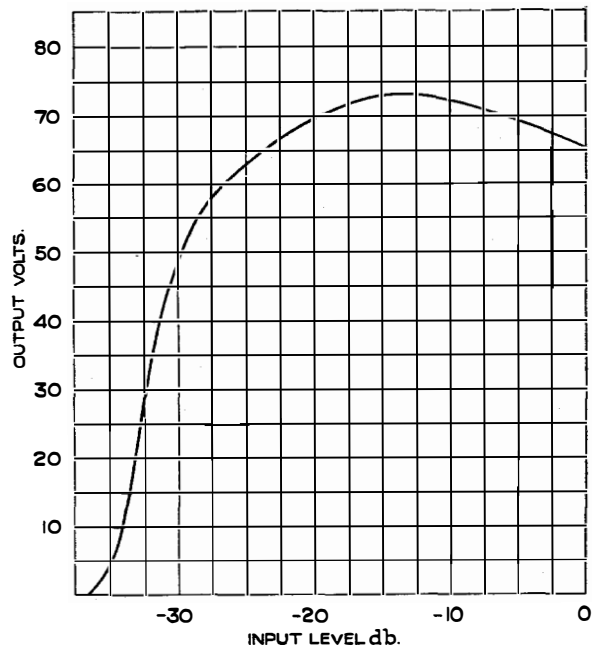

Figure 7—Relation of Input Level to Output Volts.

The characteristic of the new suppressor as shown in Figure 7 is such that its output voltage is substantially constant at about 70 volts over an input range of -5 to -25 db., a range sufficient to include the input level values which would produce an audible echo. Below the minimum voltage (30-40) required for complete

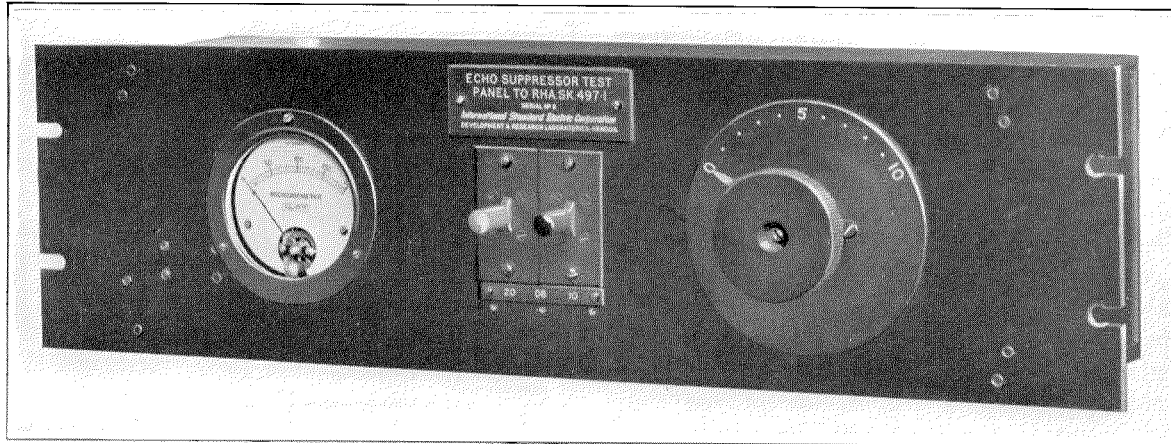

Figure 8—Testing Panel—Front View.

suppression, the output falls rapidly giving good protection against operation on noise. The hang-over time is adjustable, by means of a tapped condenser, between 80 and 200 milliseconds, no timing measurements being required. The pick-up time is between 15 and 30 milliseconds depending on the hangover setting. The sensitivity may be varied in steps of approximately 5 db. by tapplings on the input transformer.

Testing Methods

The routine testing of this suppressor is a relatively simple matter being confined in general to 1,000 p.p.s. sensitivity measurements, though occasional check tests at other frequencies may be desirable. Referring to Figure 7, three measurements only will cover the important requirements of the sensitivity curve, namely:

- (a) Input level at a point on the steep part of the curve just below the top bend.
- (b) Change in input level required to reduce the output from the value of (a) to a very small value.
- (c) Maximum output obtainable.

Test (a) checks the basic sensitivity while (b) ensures freedom from noise operation.

The only special testing apparatus necessary consists of a panel having a network giving attenuation of 40 db. in steps of 1 db. and a microammeter which when plugged into the output circuit of the suppressor indicates the rectified current and therefore gives a measure of the output voltage.

The testing panel is shown in Figure 8.

Battery Supply Circuits

The battery supply circuit of the echo suppressor is very similar to that of the 4-wire repeater comprising a filament retardation coil and adjusting resistances. In the 130 v. circuit, resistance lamps and alarm relays, are required, but no grid battery.

The alarm circuit of repeaters associated with echo suppressors requires modification, as the normal alarm, being given by a relay which is normally held operated by the repeater plate current, will operate when the plate current of the repeater is reduced by operation of the suppressor. This has been overcome by the provision of a high impedance relay connected between the windings of the existing alarm relays in the two halves of the repeater, on the battery side of the relays. This circuit is shown in Figure 9. The new relay is connected between points of approximately equal voltage under normal conditions. When the plate current in one side of the repeater is reduced by operation of the suppressor, the voltage across the alarm relay becomes of the order of 10 volts, which is insufficient for operation. If, however, there is a disconnection in the plate supply of one side of the repeater on the battery side of the alarm relays or if any point on the plate circuit in the repeater breaks down to earth, the voltage across the alarm relay rises to approximately 100 volts which is sufficient for operation. In order to give an alarm for total failure of plate current or valve filament failure the contacts of the existing alarm relays are connected in

series, so that both plate current relays must release before the alarm is given.

Field Trials

By the courtesy of the British Post Office, two field trials were made on this suppressor. The suppressor was first tested on a 500 mile medium heavy circuit, of which the two terminals and the centre point were looped back to one station, for convenience in testing and adjustment. Tests were made under a variety of conditions and the suppressor proved very satisfactory in operation with the circuit set to give zero equivalent, even when very bad echo conditions were artificially produced. But for the elimination of echo, it was impossible to detect the presence of the suppressor except during one period when bad line noise was experienced on a section of the circuit, in which case the cessation of received noise when talking indicated operation of the suppressor. In the second test, the suppressor was installed at Derby on a working circuit between London and Glasgow, and its performance over a period

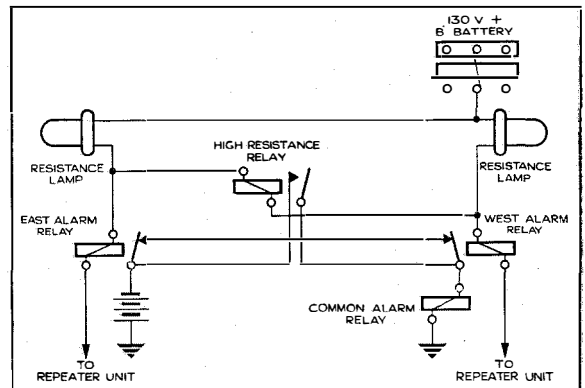

Figure 9—Modification of Repeater Alarm Circuit.

was reported by the Post Office engineers to be satisfactory from all standpoints.

Conclusion

The new echo suppressor gives a close approximation to the desirable operating characteristics of the relay type suppressor, while retaining the greater reliability and simplicity of maintenance of the valve type. In addition, the new type has advantages over the relay type in that grid batteries are avoided.

INTERNATIONAL TELEPHONE AND TELEGRAPH CORPORATION

ASSOCIATED AND AFFILIATED COMPANIES

All America Cables, Incorporated.....	New York, N. Y.
Cuban All America Cables, Incorporated, The.....	New York, N. Y.
Chili Telephone Company, Limited, The.....	Santiago, Chile
Compagnie des Téléphones Thomson-Houston.....	Paris, France
Companhia Radio Internacional do Brasil.....	Rio de Janeiro, Brazil
Companhia Telefonica Rio Grandense.....	Porto Alegre, Brazil
Compañia Internacional de Radio Argentina.....	Buenos Aires, Argentina
Compañia Internacional de Radio S. A. (Chile).....	Santiago, Chile
Compañia Peruana de Teléfonos, Limitada.....	Lima, Peru
Compañia Telefónica Argentina.....	Buenos Aires, Argentina
Compañia Telefónica Nacional de España.....	Madrid, Spain
Constantinople Telephone Company, Limited.....	Istanbul, Turkey
Creed & Company, Limited.....	Croydon, England
Creed Telegraphenapparate, G.m.b.H.....	Berlin, Germany
Cuban American Telephone and Telegraph Company.....	Havana, Cuba
Cuban Telephone Company.....	Havana, Cuba
Havana Subway Company.....	Havana, Cuba
Radio Corporation of Cuba.....	Havana, Cuba
Gesellschaft Fuer Telephon-und Telegraphenbeteiligungen m.b.H.....	Berlin, Germany
International Communications Laboratories, Inc.....	New York, N. Y.
International Marine Radio Company, Limited.....	London, England
International Standard Electric Corporation.....	New York, N. Y.
Bell Telephone Manufacturing Company.....	Antwerp, Belgium
Standard Electric Doms a Spolecnost.....	Prague, Czechoslovakia
China Electric Company, Limited.....	Shanghai, China
Compañia Standard Electric Argentina.....	Buenos Aires, Argentina
International Standard Electric Corporation of Mexico.....	New York, N. Y.
International Telephone and Telegraph Laboratories, Incorporated (Delaware).....	Hendon, England
Laboratoire International de Téléphonie et Télégraphie, Inc.....	New York, N. Y.
Le Materiel Phonique.....	Paris, France
Nippon Denki Kabushiki Kaisha.....	Tokyo, Japan
Osterreichische Telephon-Fabrik Aktiengesellschaft.....	Vienna, Austria
Standard Electric Aktieselskap.....	Oslo, Norway
Aktieselskabet Skandinaviske Kabel-Og Gummifabriker.....	Oslo, Norway
Standard Eléctrica, S. A.....	Madrid, Spain
Standard Elettrica Italiana.....	Milan, Italy
Standard Telephones and Cables, Limited.....	London, England
Standard Telephones and Cables (Australasia), Limited.....	Sydney, Australia
Standard Villamossági Részvény Társaság.....	Budapest, Hungary
Vereinigte Telephon-und Telegraphenfabriks Aktiengesellschaft, Czeija, Nissl & Co.....	Vienna, Austria
Standard Electric Company w Polsce Sp. z O. O.....	Warsaw, Poland
International Telephone and Telegraph Company, Limited.....	London, England
International Telephone and Telegraph Corporation (España).....	Madrid, Spain
Compañia Internacional de Radio (España).....	Madrid, Spain
International Telephone and Telegraph Corporation, Sud America.....	Buenos Aires, Argentina
International Telephone Building Corporation.....	New York, N. Y.
International Telephone Securities Corporation.....	New York, N. Y.
Lorenz, A. G. (C.).....	Berlin, Germany
Mexican Telephone and Telegraph Company.....	Mexico City, Mexico
Montevideo Telephone Company, Limited.....	Montevideo, Uruguay
Porto Rico Telephone Company.....	San Juan, Porto Rico
Radio Corporation of Porto Rico.....	San Juan, Porto Rico
Postal Telegraph and Cable Corporation.....	New York, N. Y.
Mackay Companies, The.....	New York, N. Y.
Commercial Cable Company, The.....	New York, N. Y.
Commercial Cable Company, Limited.....	London, England
Commercial Cable Company, The (Massachusetts).....	Boston, Mass.
Mackay Radio and Telegraph Company (California).....	San Francisco, Cal.
Mackay Radio and Telegraph Company, Inc. (Delaware).....	New York, N. Y.
Postal Telegraph System.....	New York, N. Y.
Radio Communication Company, Inc.....	New York, N. Y.
Radio Internacional, Limitada.....	Rio de Janeiro, Brazil
Shanghai Telephone Company.....	Shanghai, China
Sociedad Anonima Radio Argentina.....	Buenos Aires, Argentina
Sociedad Cooperativa Telefónica Nacional.....	Montevideo, Uruguay
Societatea Anonima Romana de Telefoane.....	Bucharest, Rumania
Standard Elektrizitäts Gesellschaft, A. G. zu Berlin.....	Berlin, Germany
Mix & Genest Aktiengesellschaft.....	Berlin, Germany
Ferdinand Schuchhardt, Berliner Fernsprech-und Telegraphenwerk Aktiengesellschaft.....	Berlin, Germany
Suddeutsche Apparate Fabrik, G.m.b.H.....	Nuremberg, Germany
Telephonfabrik Berliner Aktiengesellschaft.....	Berlin, Germany
United River Plate Telephone Company, Limited.....	Buenos Aires, Argentina
